

JVC

SERVICE MANUAL

VIDEOGRABADOR

HR-J496EN/J696EN



ESPECIFICACIONES *(The specifications shown pertain specifically to the model HR-J696EN.)*

GENERALIDADES

Alimentación	: 110 V – 220 V ~ CA, 50 Hz/60 Hz
Consumo	
Alimentación conectada	: 16 W
Alimentación desconectada	: 4,5 W
Temperatura	
De funcionamiento	: 5°C a 40°C (41°F a 104°F)
De almacenamiento	: -20°C a 60°C (-4°F a 140°F)
Posición de funcionamiento	: Únicamente horizontal
Dimensiones (An x Al x Pr)	: 400 mm x 94 mm x 250 mm
Peso	: 3,3 kg
Formato	: Norma VHS NTSC
Tiempo máximo de grabación	
SP	: 240 minutos con un videocassette E-240 (PAL-N) : 160 minutos con un videocassette T-160 (NTSC)
LP	: 480 minutos con un videocassette E-240 (PAL-N)
EP	: 480 minutos con un videocassette T-160 (NTSC)

VIDEO/AUDIO

Sistema de señales	: Señales de color tipo PAL-N y señales monocromas EIA, 625 líneas/50 campos, Señales cromáticas NTSC y señales monocromas EIA, 525 líneas/60 campos (solo para reproducción)
Sistema de grabación/reproducción	: Sistema de exploración helicoidal de 4 cabezas DA-4 (doble acimut)
Relación señal a ruido	: 45 dB
Resolución horizontal	: 240 líneas (PAL-N) 230 líneas (NTSC)
Gama de frecuencia	
Audio normal	: 70 Hz a 10,000 Hz
Audio de alta fidelidad	: 20 Hz a 20,000 Hz
Entrada/salida	: Conectores RCA (IN x 2, OUT x 1)

SINTONIZADOR

Sistema de sintonía	: Sintonizador de frecuencia sintetizada
Cobertura de canales	
VHF	: Canales 2–13
UHF	: Canales 14–69
CATV	: 113 canales
Salida de RF	: Canal 3 ó 4 (conmutable; preajustado en fábrica al canal 3) 75 Ω , asimétrica

TEMPORIZADOR

Referencia de reloj	: Cuarzo
Capacidad de programación	: Temporizador programable para 1 año/8 programas
Tiempo de protección de la memoria	: Aprox. 6 meses Cifra estimada pasada en la pila nueva suministrada; el rendimiento real puede ser diferente.

ACCESORIOS

Accesorios suministrados	: Cable RF, Pila de litio CR2025, Unidad de control remoto por infrarrojos, Pila "AA" x 2
--------------------------	--

A menos que se especifique lo contrario, las especificaciones dadas son para el modo SP.
El diseño y las especificaciones se encuentran sujetos a cambios sin previo aviso.

TABLE OF CONTENTS

Section	Title	Page	Section	Title	Page
Important Safety Precautions					
INSTRUCTIONS					
1. DISASSEMBLY					
1.1	DISASSEMBLY FLOW CHART	1-1	2.3	COMPATIBILLTIY ADJUSTMENT	2-16
1.2	HOW TO READ THE DISASSEMBLY AND ASSEMBLY	1-1	2.3.1	FM waveform linearity	2-16
1.3	DISASSEMBLY /ASSEMBLY METHOD	1-1	2.3.2	Height and tilt of the A/C head	2-17
1.4	Service position	1-4	2.3.3	A/C head phase (X-value)	2-17
1.4.1	How to set the "Service position"	1-4	2.3.4	Standard tracking preset	2-18
1.5	Mechanism service mode	1-4	2.3.5	Tension pole position	2-18
1.5.1	How to set the "Mechanism service mode"	1-4	3. ELECTRICAL ADJUSTMENT		
1.6	Jig RCU mode	1-4	3.1	PRECAUTION	3-1
1.6.1	Setting the Jig RCU mode	1-4	3.1.1	Required test equipments	3-1
1.6.2	Setting the User RCU mode	1-4	3.1.2	Required adjustment tools	3-1
1.7	Emergency display function	1-5	3.1.3	Color (colour) bar signal,color (colour) bar pattern	3-1
1.7.1	Displaying the EMG information	1-5	3.1.4	Switch settings and standard precautions	3-1
1.7.2	Clearing the EMG history	1-5	3.2	SERVO CIRCUIT	3-2
1.7.3	EMG content description	1-6	3.2.1	Switching point	3-2
1.7.4	EMG detail information <1>	1-7	3.2.2	Slow tracking preset	3-2
1.7.5	EMG detail information <2>	1-8	3.3	VIDEO CIRCUIT	3-2
2. MECHANISM ADJUSTMENT			3.3.1	Auto picture initial settings	3-2
2.1	BEFORE STARTING REPAIR AND ADJUSTMENT	2-1	3.4	SYSCON CIRCUIT	3-2
2.1.1	Precautions	2-1	3.4.1	Timer clock	3-2
2.1.2	Checking for proper mechanical operations	2-1	4. CHARTS AND DIAGRAMS		
2.1.3	Manually removing the cassette tape	2-1	4.1	BOARD INTERCONNECTIONS	4-3
2.1.4	Jigs and tools required for adjustment	2-2	4.2	MAIN (VIDEO/AUDIO) SCHEMATIC DIAGRAM	4-5
2.1.5	Maintenance and inspection	2-3	4.3	MAIN (SYSCON) AND LT BATTERY SCHEMATIC DIAGRAMS	4-7
2.2	REPLACEMENT OF MAJOR PARTS	2-6	4.4	MAIN (SW.REG) SCHEMATIC DIAGRAM	4-9
2.2.1	Before starting disassembling (Phase matching between mechanical parts)	2-6	4.5	MAIN (TUNER) SCHEMATIC DIAGRAM	4-11
2.2.2	How to set the "Mechanism assembling mode"	2-6	4.6	MAIN (FMA/DEMODO) SCHEMATIC DIAGRAM [HR-J693M/J696EN]	4-13
2.2.3	Cassette holder assembly	2-6	4.7	MAIN (FRONT) SCHEMATIC DIAGRAM	4-15
2.2.4	Pinch roller arm assembly	2-8	4.8	MAIN (TERMINAL) SCHEMATIC DIAGRAMS	4-17
2.2.5	Guide arm assembly and press lever assembly	2-8	4.9	MAIN CIRCUIT BOARD	4-19
2.2.6	Audio control head	2-8	4.10	ADV. JOG SCHEMATIC DIAGRAM [HR-J696EN]	4-21
2.2.7	Loading motor	2-8	4.11	REMOTE CONTROLLER SCHEMATIC DIAGRAM ...	4-22
2.2.8	Capstan motor	2-9	4.12	FDP GRID ASSIGNMET AND ANODE CONNECTION	4-23
2.2.9	Pole base assembly (supply or take-up side)	2-9	4.13	WAVEFORMS	4-24
2.2.10	Rotary encoder	2-10	4.14	VOLTAGE CHARTS	4-25
2.2.11	Clutch unit	2-10	4.15	CPU PIN FUNCTION	4-26
2.2.12	Change lever assembly,direct gear,clutch gear and coupling gear	2-10	4.16	SYSTEM CONTROL BLOCK DIAGRAM	4-27
2.2.13	Link lever	2-11	4.17	VIDEO BLOCK DIAGRAM	4-29
2.2.14	Cassette gear,control cam and worm gear	2-11	4.18	AUDIO BLOCK DIAGRAM	4-31
2.2.15	Control plate	2-11	5. PARTS LIST		
2.2.16	Loading arm gear (supply or take-up side) and loading arm gear shaft	2-12	5.1	PACKING AND ACCESSORY ASSEMBLY <M1>	5-1
2.2.17	Take-up lever,take-up head and control plate guide ...	2-13	5.2	FINAL ASSEMBLY <M2>	5-2
2.2.18	Capstan brake assembly	2-13	5.3	MECHANISM ASSEMBLY <M4>	5-4
2.2.19	Sub brake assembly (take-up side)	2-13	5.4	ELECTRICAL PARTS LIST	5-6
2.2.20	Main brake assembly (take-up side), reel disk (take-up side) and main brake assembly (supply side)	2-13	MAIN BOARD ASSEMBLY <03>		
2.2.21	Tension brake assembly, reel disk (supply side) and tension arm assembly	2-14	A/C HEAD BOARD ASSEMBLY<12>		
2.2.22	Idler lever, idler arm assembly	2-14	ADV. JOG BOARD ASSEMBLY<38>[HR-J696EN]		
2.2.23	Stator assembly	2-14	LOADING MOTOR BOARD ASSEMBLY <55>		
2.2.24	Rotor assembly	2-14	LT BATTERY BOARD ASSEMBLY <93>		
2.2.25	Upper drum assembly	2-15			

The following table indicate main different points between models HR-J496EN and HR-J696EN.

ITEM	MODEL	HR-J496EN	HR-J696EN
DIMESIONS (WxHxD)mm		360x94x212	400x94x212
JOG/SHUTTLE DIAL ON DECK		NOT USED	USED
VIDEO ACTION:SLOWMOTION(FWD)		+1/6	±1/6,+1/18
VIDEO ACTION:SLOWMOTION(REV)		NOT USED	±1/6,-1/18
L-1 in		VIDEO x 1,AUDIO(MONO)	VIDEO x 1,AUDIO(L,R)
AV out		VIDEO x 1,AUDIO(MONO)	VIDEO x 1,AUDIO(L,R)
HI-FI AUDIO		NO	YES
STEREO DECODER		NO	YES
REC LINK / INPUT		NO	YES

Important Safety Precautions

Prior to shipment from the factory, JVC products are strictly inspected to conform with the recognized product safety and electrical codes of the countries in which they are to be sold. However, in order to maintain such compliance, it is equally important to implement the following precautions when a set is being serviced.

● Precautions during Servicing

1. Locations requiring special caution are denoted by labels and inscriptions on the cabinet, chassis and certain parts of the product. When performing service, be sure to read and comply with these and other cautionary notices appearing in the operation and service manuals.

2. Parts identified by the \triangle symbol and shaded (■) parts are critical for safety.
Replace only with specified part numbers.
Note: Parts in this category also include those specified to comply with X-ray emission standards for products using cathode ray tubes and those specified for compliance with various regulations regarding spurious radiation emission.

3. Fuse replacement caution notice.
Caution for continued protection against fire hazard.
Replace only with same type and rated fuse(s) as specified.

4. Use specified internal wiring. Note especially:
1) Wires covered with PVC tubing
2) Double insulated wires
3) High voltage leads

5. Use specified insulating materials for hazardous live parts.
Note especially:
1) Insulation Tape 3) Spacers 5) Barrier
2) PVC tubing 4) Insulation sheets for transistors

6. When replacing AC primary side components (transformers, power cords, noise blocking capacitors, etc.) wrap ends of wires securely about the terminals before soldering.

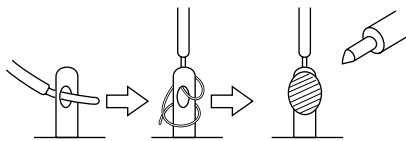

Fig.1

7. Observe that wires do not contact heat producing parts (heatsinks, oxide metal film resistors, fusible resistors, etc.)

8. Check that replaced wires do not contact sharp edged or pointed parts.

9. When a power cord has been replaced, check that 10-15 kg of force in any direction will not loosen it.

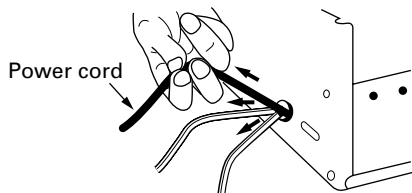

Fig.2

10. Also check areas surrounding repaired locations.

11. Products using cathode ray tubes (CRTs)
In regard to such products, the cathode ray tubes themselves, the high voltage circuits, and related circuits are specified for compliance with recognized codes pertaining to X-ray emission. Consequently, when servicing these products, replace the cathode ray tubes and other parts with only the specified parts. Under no circumstances attempt to modify these circuits. Unauthorized modification can increase the high voltage value and cause X-ray emission from the cathode ray tube.

12. Crimp type wire connector

In such cases as when replacing the power transformer in sets where the connections between the power cord and power transformer primary lead wires are performed using crimp type connectors, if replacing the connectors is unavoidable, in order to prevent safety hazards, perform carefully and precisely according to the following steps.

1) **Connector part number** : E03830-001

2) **Required tool** : Connector crimping tool of the proper type which will not damage insulated parts.

3) **Replacement procedure**

(1) Remove the old connector by cutting the wires at a point close to the connector.

Important : Do not reuse a connector (discard it).

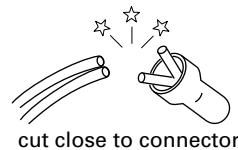

Fig.3

(2) Strip about 15 mm of the insulation from the ends of the wires. If the wires are stranded, twist the strands to avoid frayed conductors.

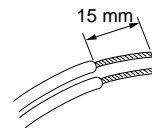

Fig.4

(3) Align the lengths of the wires to be connected. Insert the wires fully into the connector.

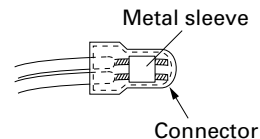

Fig.5

(4) As shown in Fig.6, use the crimping tool to crimp the metal sleeve at the center position. Be sure to crimp fully to the complete closure of the tool.

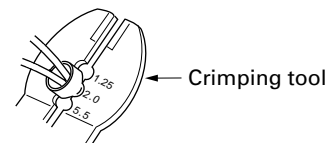

Fig.6

(5) Check the four points noted in Fig.7.

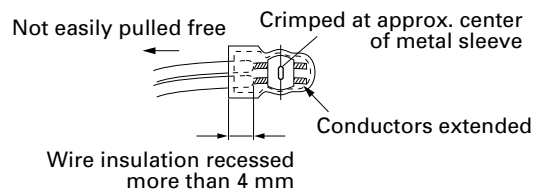

Fig.7

● Safety Check after Servicing

Examine the area surrounding the repaired location for damage or deterioration. Observe that screws, parts and wires have been returned to original positions. Afterwards, perform the following tests and confirm the specified values in order to verify compliance with safety standards.

1. Insulation resistance test

Confirm the specified insulation resistance or greater between power cord plug prongs and externally exposed parts of the set (RF terminals, antenna terminals, video and audio input and output terminals, microphone jacks, earphone jacks, etc.). See table 1 below.

2. Dielectric strength test

Confirm specified dielectric strength or greater between power cord plug prongs and exposed accessible parts of the set (RF terminals, antenna terminals, video and audio input and output terminals, microphone jacks, earphone jacks, etc.). See table 1 below.

3. Clearance distance

When replacing primary circuit components, confirm specified clearance distance (d), (d') between soldered terminals, and between terminals and surrounding metallic parts. See table 1 below.

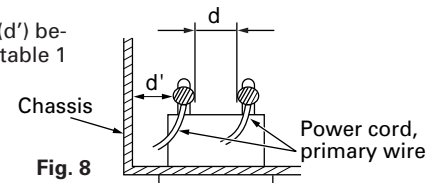

4. Leakage current test

Confirm specified or lower leakage current between earth ground/power cord plug prongs and externally exposed accessible parts (RF terminals, antenna terminals, video and audio input and output terminals, microphone jacks, earphone jacks, etc.).

Measuring Method : (Power ON)

Insert load Z between earth ground/power cord plug prongs and externally exposed accessible parts. Use an AC voltmeter to measure across both terminals of load Z. See figure 9 and following table 2.

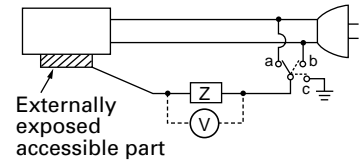

5. Grounding (Class I model only)

Confirm specified or lower grounding impedance between earth pin in AC inlet and externally exposed accessible parts (Video in, Video out, Audio in, Audio out or Fixing screw etc.).

Measuring Method:

Connect milli ohm meter between earth pin in AC inlet and exposed accessible parts. See figure 10 and grounding specifications.

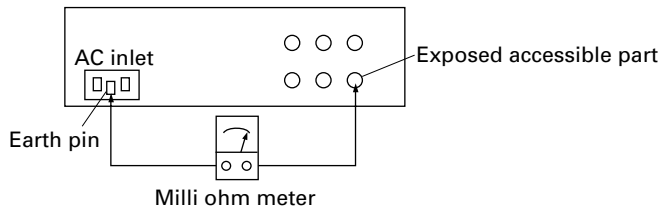

Grounding Specifications

Region	Grounding Impedance (Z)
USA & Canada	$Z \leq 0.1 \text{ ohm}$
Europe & Australia	$Z \leq 0.5 \text{ ohm}$

Fig. 10

AC Line Voltage	Region	Insulation Resistance (R)	Dielectric Strength	Clearance Distance (d), (d')
100 V	Japan	$R \geq 1 \text{ M}\Omega/500 \text{ V DC}$	AC 1 kV 1 minute	$d, d' \geq 3 \text{ mm}$
100 to 240 V			AC 1.5 kV 1 minute	$d, d' \geq 4 \text{ mm}$
110 to 130 V	USA & Canada	$1 \text{ M}\Omega \leq R \leq 12 \text{ M}\Omega/500 \text{ V DC}$	AC 1 kV 1 minute	$d, d' \geq 3.2 \text{ mm}$
110 to 130 V 200 to 240 V	Europe & Australia	$R \geq 10 \text{ M}\Omega/500 \text{ V DC}$	AC 3 kV 1 minute (Class II) AC 1.5 kV 1 minute (Class I)	$d \geq 4 \text{ mm}$ $d' \geq 8 \text{ mm}$ (Power cord) $d' \geq 6 \text{ mm}$ (Primary wire)

Table 1 Specifications for each region

AC Line Voltage	Region	Load Z	Leakage Current (i)	a, b, c
100 V	Japan		$i \leq 1 \text{ mA rms}$	Exposed accessible parts
110 to 130 V	USA & Canada		$i \leq 0.5 \text{ mA rms}$	Exposed accessible parts
110 to 130 V 220 to 240 V	Europe & Australia		$i \leq 0.7 \text{ mA peak}$ $i \leq 2 \text{ mA dc}$	Antenna earth terminals
			$i \leq 0.7 \text{ mA peak}$ $i \leq 2 \text{ mA dc}$	Other terminals

Table 2 Leakage current specifications for each region

Note: These tables are unofficial and for reference only. Be sure to confirm the precise values for your particular country and locality.

SECTION 1 DISASSEMBLY

1.1 DISASSEMBLY FLOW CHART

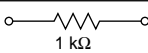
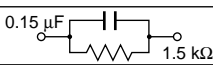
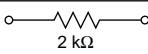
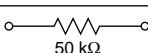
This flowchart lists the disassembling steps for the cabinet parts and P.C. boards in order to gain access to item(s) to be serviced. When reassembling, perform the step(s) in reverse order. Bend, route and dress the flat cables as they were originally laid.

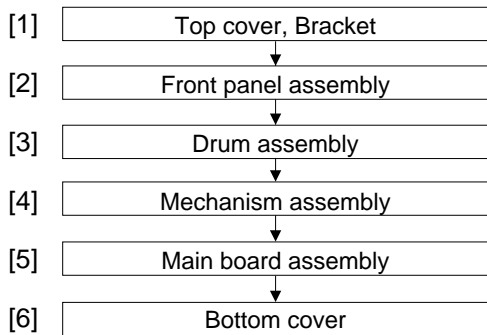

1.2 HOW TO READ THE DISASSEMBLY AND ASSEMBLY

<Example>

Step/ LocNo.	Part Name	Fig. No.	Point	Note
①	Top cover, Bracket	D1	4(S1a),(S1b),3(L1a), 2(SD1a),(P1a), CN1(WR1a), 2(S1c)	<Note 1>

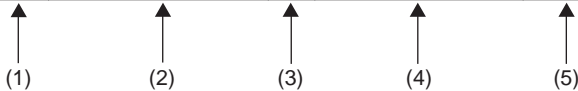

- (1) Order of steps in Procedure
When reassembling, perform the step(s) in the reverse order. These numbers are also used as the identification (location) No. of parts Figures.
- (2) Part name to be removed or installed.
- (3) Fig. No. showing procedure or part location.
- (4) Identification of part to be removed, unhooked, unlocked, released, unplugged, unclamped or unsoldered.
P= Spring, W= Washer, S= Screw, L= Locking tab, SD= Solder, CN**(WR**)= Remove the wire (WR**) from the connector (CN**).

Note:

- The bracketed () WR of the connector symbol are assigned nos. in priority order and do not correspond to those on the spare parts list.

- (5) Adjustment information for installation

1.3 DISASSEMBLY/ASSEMBLY METHOD

Step/ LocNo.	Part Name	Fig. No.	Point	Note
①	Top cover Bracket	D1	2(S1a) ----- 2(S1b)	
②	Front panel assembly (HR-J496EN) ----- Front panel assembly (HR-J696EN) ADV.JOG board assembly	D2 ----- D2	7(L2) ----- 7(L2) CN7001(WR2) 2(S2)	<Note 2a> <Note 2b> ----- <Note 3>
③	Drum assembly Cleaner assembly	D3	3(S3), CON3(WR3a), CN3(WR3b) ----- (L3c)	<Note 3>
④	Mechanism assembly	D4	2(S4a), (S4b),(S4c) 2(L4), CN2001(WR4)	<Note 3> <Note 4>
⑤	Main board assembly	D5	3(S5a),(S5b),(S5c) 2(L5b),2(L5c)	
⑥	Bottom cover	D6	2(L6a),5(L6b),2(L6c)	<Note 6>

<Note 2a>

- When reattaching the Front panel assembly, make sure that the door opener (a) of the Cassette holder assembly is lowered in position prior to the reinstallation.

<Note 2b>

- When reattaching the Front panel assembly, pay careful attention to the switch lever not to make it touch the switch knob (b) of the Main board assembly from the side. (If the switch knob of the Main board assembly is damaged, cassette loading is impossible.)

<Note 3>

- Be careful not to damage the connector and wire etc. during connection and disconnection.
When connecting the wire to the connector, be careful with the wire direction.

<Note 4>

- When it is required to remove the screws (S4a) retaining the Mechanism assembly, please refer to the "Procedures for Lowering the Cassette holder assembly"(See on page 1-2).x
- The wire (WR4) has excess length that may be loose, as it is quite long. After inserting the wire and connectors, the loose portion of the wire should be taken up and accommodated between the A/C head base and the main deck.
- When reattaching the Mechanism assembly to the Main board assembly, take care not to damage the sensors on the Main board assembly (D3001: LED, Q3002: End sensor).

<Note 6>

- When removing the bottom cover, push down the two tabs (L6a) to slide the bottom cover.

Procedures for Lowering the Cassette holder assembly

As the mechanism of this unit is integrated with the Housing assembly, the holder must be lowered and the two screws unscrewed when removing the Mechanism assembly.

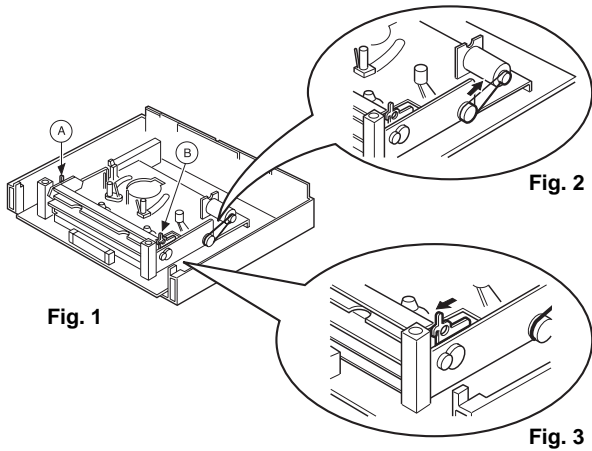

Turn the loading motor pulley in the direction as indicated by Fig.2. As both **A** and **B** levers are lodged twice, push the levers in the direction as indicated by Fig.3 to release them. When pushing the levers, do it in the order of **A**, **B**, **B**, **A**. When the holder has been lowered, turn the pulley until the cassette holder is securely in place without allowing any up/down movement.

Procedures for Lowering the Cassette holder assembly

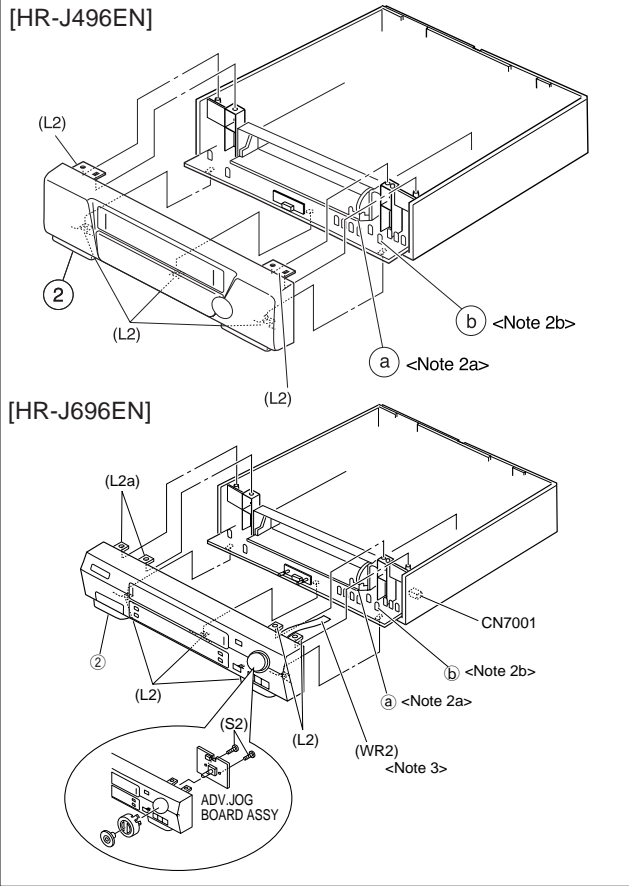

Fig. D2

Note:

- When installing the DRUM assembly, secure the screws (S3) in the order of (a), (b), (c).

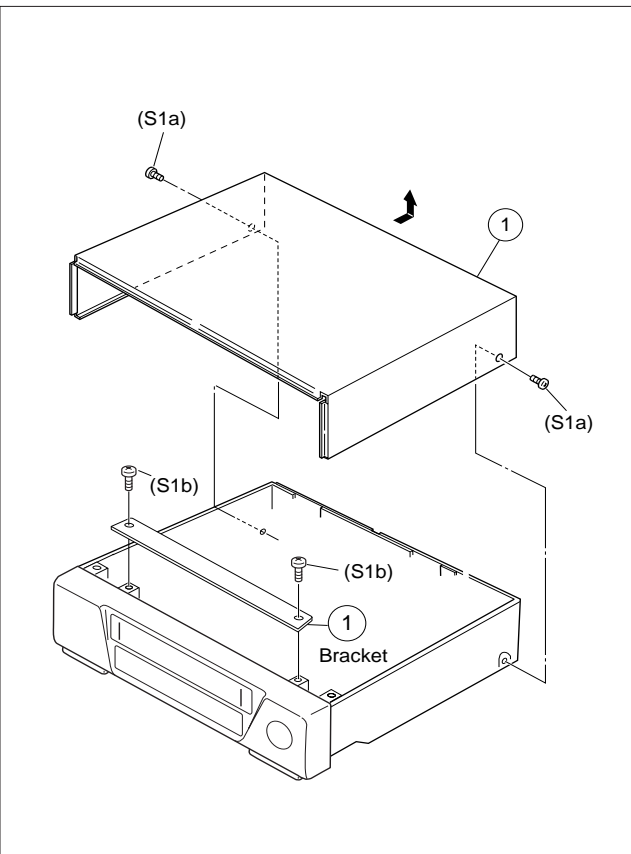

Fig. D1

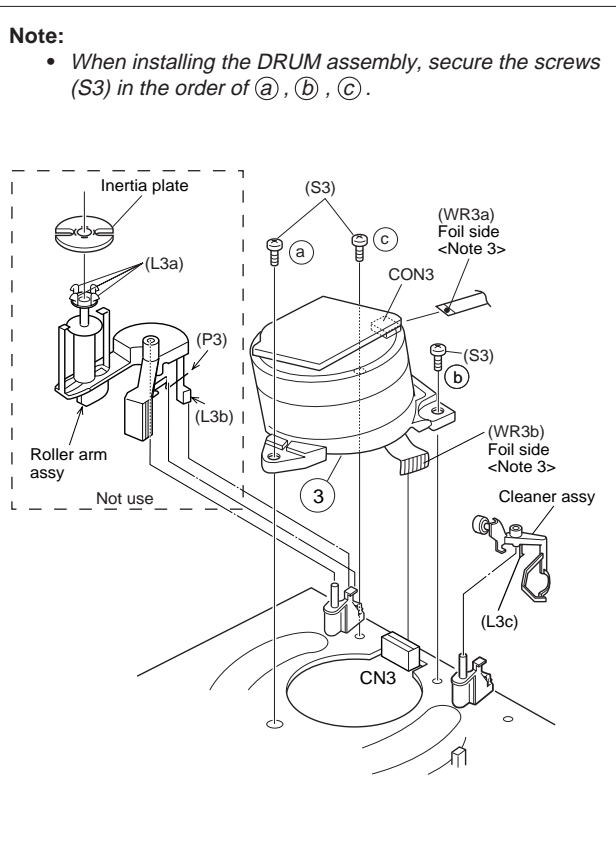

Fig. D3

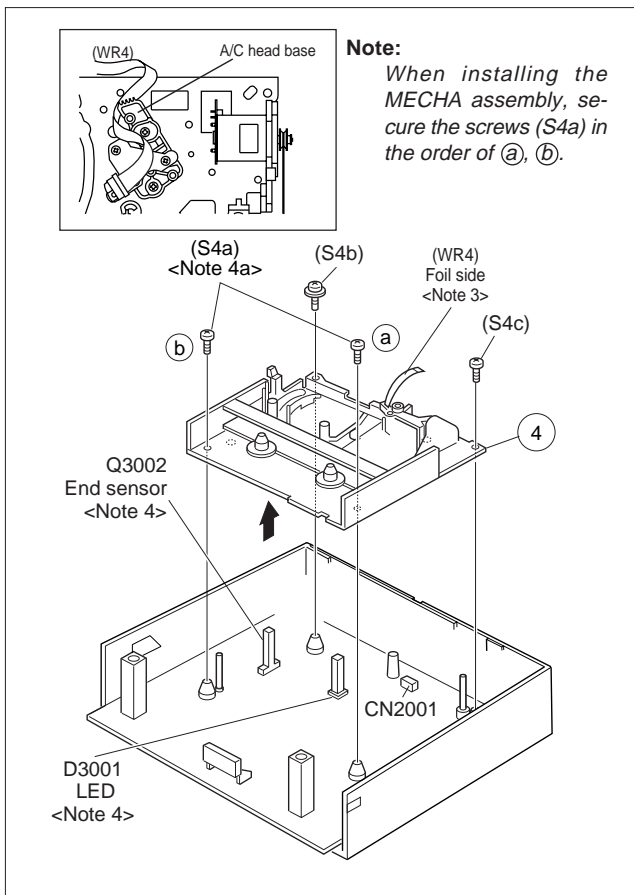

Fig. D4

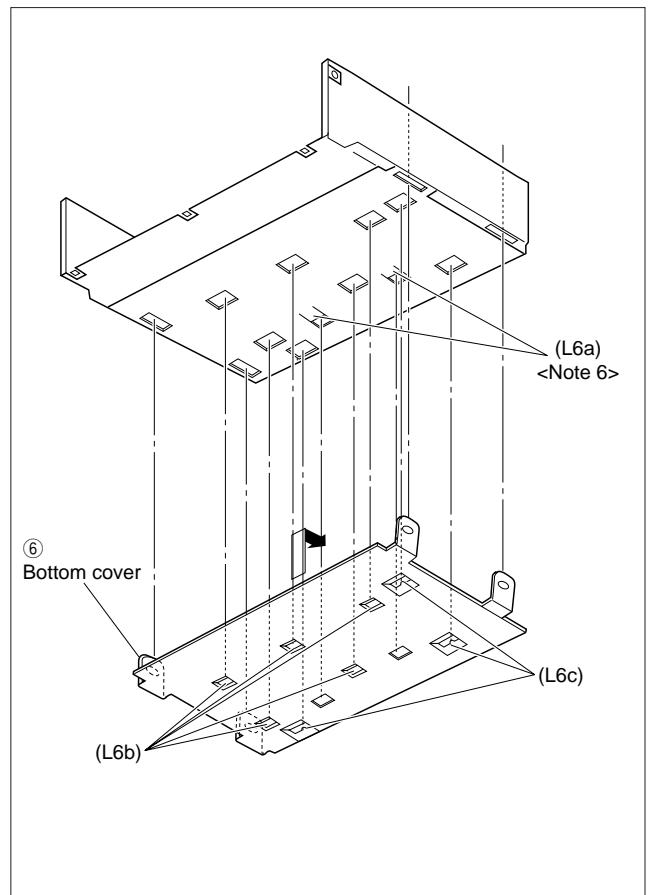

Fig. D6

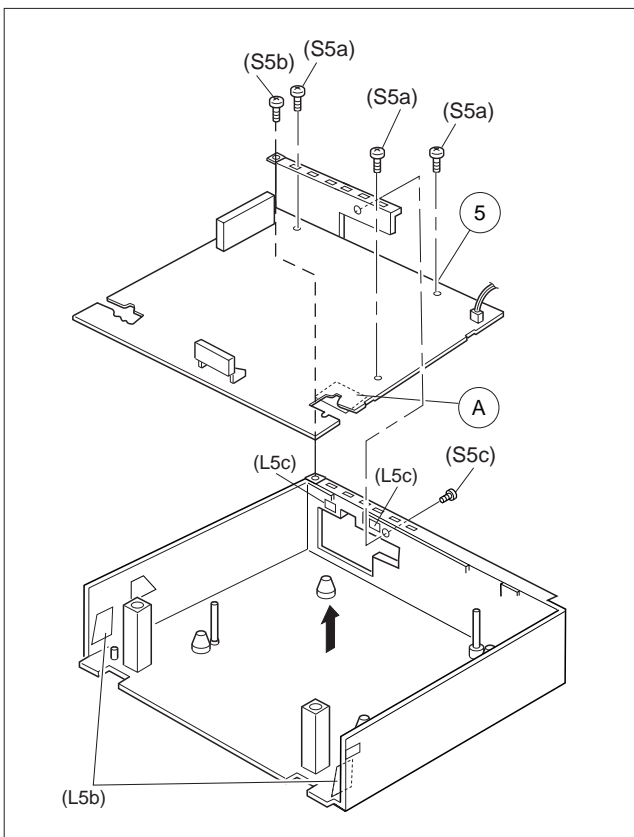

Fig. D5

Fig D5 Note 1:

- Make sure that the (L5b) remains mounted on the main board during assembly.

Fig D5 Note 2:

- If you hold with your hands the RF connector and (A), and apply some pressure to turn them counterclockwise, you can then remove the main board.

Fig D5 Note 3:

- It is feared that the main board may be broken if it is removed due to the presence of some cutout blanks, especially when it is removed with a MECHA assembly mounted on it.

1.4 Service position

This unit has been designed so that the Mechanism and Main board assemblies can be removed together from the chassis assembly. Before diagnosing or servicing the circuit boards, take out the major parts from the chassis assembly.

1.4.1 How to set the "Service position"

- (1) Refer to the disassembly procedure and perform the disassembly of the major parts before removing the Drum assembly.
- (2) Lower the cassette holder to prepare for the removal of the Mechanism assembly screws. (Refer to the "Procedures for lowering the Cassette holder assembly" of 1.3 Disassembly/assembly method.)
- (3) Remove the combined Mechanism and Main board assemblies.
- (4) Connect the wires and connectors of the major parts that have been removed in step (1). (Refer to Fig.1-4-1a.)
- (5) Place the combined Mechanism and Main board assemblies upside down.
- (6) Insert the power cord plug into the power outlet and then proceed with the diagnostics and servicing of the board assembly.

Notes:

- Before inserting the power cord plug into the power outlet, make sure that none of the electrical parts are able to short-circuit between the workbench and the board assembly.
- For the disassembly procedure of the major parts and details of the precautions to be taken, see "1.3 Disassembly/assembly method".
- If there are wire connections from the Main board and Mechanism assemblies to the other major parts, be sure to remove them (including wires connected to the major parts) first before performing step (2).
- When carrying out diagnosis and repair of the Main board assembly in the "Service position", be sure to ground both the Main board and Mechanism assemblies. If they are improperly grounded, there may be noise on the playback picture or FDP counter display may move even when the mechanism is kept in an in-operative status.
- In order to diagnose the playback or recording of the cassette tape, set the Mechanism assembly to the required mode before placing it upside down. If the mechanism mode is changed (including ejection) while it is in an upside down position the tape inside may be damaged.
- The mechanism and board assemblies of this unit are attached by connectors only. When carrying out a diagnosis or repair of the boards in the "Service position", make sure that the connectors are not disconnected.

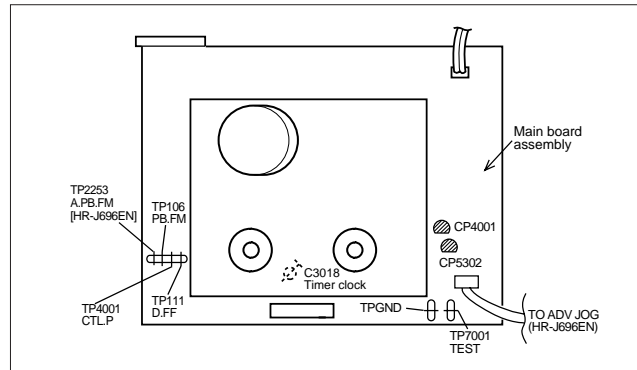

Fig. 1-4-1a

1.5 Mechanism service mode

This model has a unique function to enter the mechanism into every operation mode without loading of any cassette tape. This function is called the "Mechanism service mode".

1.5.1 How to set the "Mechanism service mode"

- (1) Unplug the power cord plug from the power outlet.
- (2) Connect TPGND and TP7001 (TEST) on the Main board assembly with a jump wire.
- (3) Insert the power cord plug into the power outlet.
- (4) With lock levers (A) (B) on the left and right of the Cassette holder assembly pulled toward the front, slide the holder in the same direction as the cassette insertion direction. (For the positions of lock levers (A) (B), refer to the "Procedures for lowering the Cassette holder assembly" of 1.3 Disassembly/assembly method.)
- (5) The cassette holder lowers and, when the loading has completed, the mechanism enters the desired mode.

1.6 Jig RCU mode

This unit uses the following two modes for receiving remote control codes.

- 1) User RCU mode : Ordinary mode for use by the user.
- 2) Jig RCU mode : Mode for use in production and servicing.

When using the Jig RCU, it is required to set the VCR to the Jig RCU mode (the mode in which codes from the Jig RCU can be received). As both of the above two modes are stored in the EEPROM, it is required to set the VCR back to the User RCU mode each time that an adjustment is made or to check that the necessary operations have been completed. These modes can be set by the operations described below.

1.6.1 Setting the Jig RCU mode

- (1) Unplug the power cord plug from the power outlet.
- (2) Press and hold the "REC" and "PAUSE" buttons on the VCR simultaneously, while plugging the power cord plug into the power outlet.
When the VCR is set to the Jig RCU mode, the symbols (" : ") in the time display of the FDP are turned off.

1.6.2 Setting the User RCU mode

- (1) Turn off the power.
- (2) Press the "REC" and "PAUSE" buttons of the VCR simultaneously. Alternatively, transmit the code "80" from the Jig RCU.

1.7 Emergency display function

This unit has a function for storing the history of the past two emergencies (EMG) and displaying them on each FDP (or OSD). With the status of the VCR and mechanism at the moment an emergency occurred can also be confirmed.

FDP display model

[FDP display]

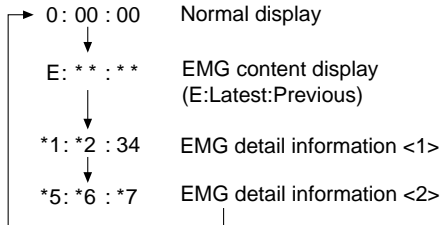

FDP (7segment LED) display model

[FDP display]

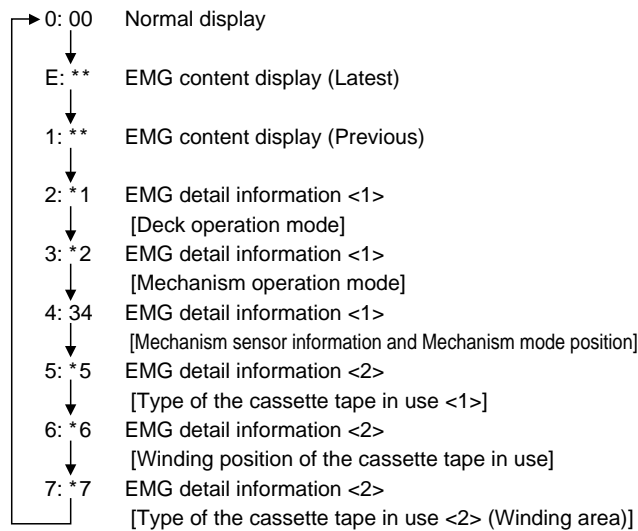

OSD display model

[OSD display]

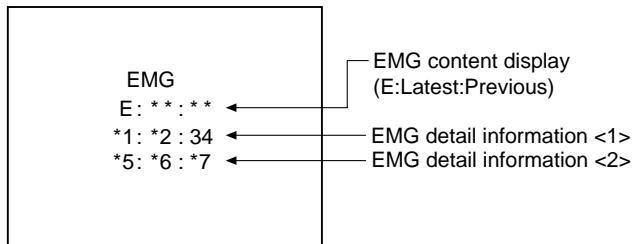

Notes:

- The EMG detail information <1><2> show the information on the latest EMG.
It becomes “-- : -- : --” when there is no latest EMG record.
- When using the Jig RCU, it is required to set the VCR to the Jig RCU mode (the mode in which codes from the Jig RCU can be received).

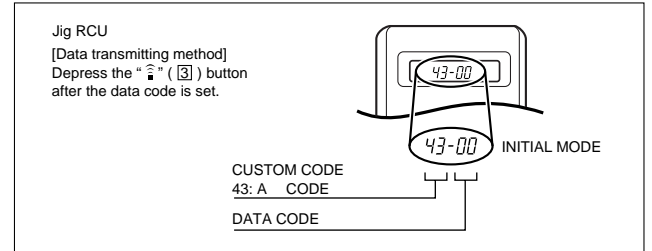
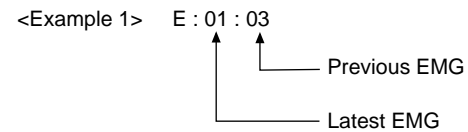

Fig. 1-7a Jig RCU [PTU94023B]

1.7.1 Displaying the EMG information

- (1) Transmit the code “59” from the Jig RCU.

The FDP shows the EMG content in the form of “E: * * : * *”.



- (2) Transmit the code “59” from the Jig RCU again.
The FDP shows the EMG detail information <1> in the form of “*1: *2 : 34”.
*1 : Deck operation mode at the moment of EMG
*2 : Mechanism operation mode at the moment of EMG
3- : Mechanism sensor information at the moment of EMG
-4 : Mechanism mode position at the moment of EMG
- (3) Transmit the code “59” from the Jig RCU once again.
The FDP shows the EMG detail information <2> in the form of “*5: *6 : *7”.
*5 : Type of the cassette tape in use <1> .
*6 : Winding position of the cassette tape in use
*7 : Type of the cassette tape in use <2> (Winding area)
- (4) Transmit the code “59” from the Jig RCU once again to reset the display.

Notes:

- For the OSD display model, all EMG information are showed by transmitting first code from the Jig RCU.
- For the EMG content, see “1.7.3 EMG content description”.
- For the EMG detail information <1>, see “1.7.4 EMG detail information <1>”.
- For the EMG detail information <2>, see “1.7.5 EMG detail information <2>”.

1.7.2 Clearing the EMG history

- (1) Display the EMG history.
- (2) Transmit the code “36” from the Jig RCU.
- (3) Reset the EMG display.

1.7.3 EMG content description

Note: EMG contents “E08/E09” are for the model with Dynamic Drum (DD).

FDP	CONTENT	CAUSE
E01: Loading EMG	When the mechanism mode cannot be changed to another mode even when the loading motor has rotated for more than 4 seconds in the loading direction, [E:01] is identified and the power is turned off.	<ol style="list-style-type: none"> The mechanism is locked in the middle of mode transition. The mechanism is locked at the loading end due to the encoder position reading error during mode transition. Power is not supplied to the loading MDA.
E02: Unloading EMG	When the mechanism mode cannot be changed to another mode even when the loading motor has rotated for more than 4 seconds in the unloading direction, [E:02] is identified and the power is turned off.	<ol style="list-style-type: none"> The mechanism is locked in the middle of mode transition. The mechanism is locked at the unloading end due to the encoder position reading error during mode transition. Power is not supplied to the loading MDA.
E03: Take Up Reel Pulse EMG	When the take-up reel pulse has not been generated for more than 4 seconds in the capstan rotating mode, [E:03] is identified, the pinch rollers are turned off and stopped, and the power is turned off. However, the reel EMG is not detected in STILL/SLOW modes.	<ol style="list-style-type: none"> The take-up reel pulse is not generated in the FWD transport modes (PLAY/FWD SEARCH/FF, etc.) because; <ol style="list-style-type: none"> The idler gear is not meshed with the take-up reel gear; The idler gear is meshed with the take-up reel gear, but incapable of winding due to too large mechanical load (abnormal tension); The take-up reel sensor does not output the FG pulse. The supply reel pulse is not generated in the REV transport modes (REV SEARCH/REW, etc.) because; <ol style="list-style-type: none"> The idler gear is not meshed with the supply reel gear. The idler gear is meshed with the supply reel gear, but incapable of winding due to too large a mechanical load (abnormal tension); The supply reel sensor does not output the FG pulse. Power is not supplied to the reel sensors.
E04: Drum FG EMG	When the drum FG pulse has not been input for more than 3 seconds in the drum rotating mode, [E:04] is identified, the pinch rollers are turned off and stopped, and the power is turned off.	<ol style="list-style-type: none"> The drum could not start or the drum rotation has stopped due to too large a load on the tape, because; <ol style="list-style-type: none"> The tape tension is abnormally high; The tape is damaged or a foreign object (grease, etc.) adheres to the tape. The drum FG pulse did not reach the System controller CPU because; <ol style="list-style-type: none"> The signal circuit is disconnected in the middle; The FG pulse generator (hall device) of the drum is faulty. The drum control voltage (DRUM CTL V) is not supplied to the MDA. Power is not supplied to the drum MDA.
E05: Cassette Eject EMG	When the eject operation does not complete in 3 seconds after the start, [E:05] is identified, the pinch rollers are turned off and stopped, and the power is turned off. When the cassette insertion operation does not complete in 3 seconds after the start, the cassette is ejected. In addition, when the operation does not complete within 3 seconds after the start, [E:05] is also identified and the power is turned off immediately.	<ol style="list-style-type: none"> The cassette cannot be ejected due to a failure in the drive mechanism of the housing. When the housing load increases during ejection, the loading motor is stopped because of lack of headroom in its drive torque. Housing load increasing factors: Temperature environment (low temperature, etc.), mechanism wear or failure. The sensor/switch for detecting the end of ejection are not functioning normally. The loading motor drive voltage is lower than specified or power is not supplied to the motor (MDA). When the user attempted to eject a cassette, a foreign object (or perhaps the user's hand) was caught in the opening of the housing.
E06: Capstan FG EMG	When the capstan FG pulse has not been generated for more than 1 second in the capstan rotating mode, [E:06] is identified, the pinch rollers are turned off and stopped, and the power is turned off. However, the capstan EMG is not detected in STILL/SLOW/FF/REW modes.	<ol style="list-style-type: none"> The capstan could not start or the capstan rotation has stopped due to too large a load on the tape, because; <ol style="list-style-type: none"> The tape tension is abnormally high (mechanical lock); The tape is damaged or a foreign object (grease, etc.) is adhered to the tape (occurrence of tape entangling, etc.). The capstan FG pulse did not reach the System controller CPU because; <ol style="list-style-type: none"> The signal circuit is disconnected in the middle; The FG pulse generator (MR device) of the capstans is faulty. The capstan control voltage (CAPSTAN CTL V) is not supplied to the MDA. Power is not supplied to the capstan MDA.
E07: SW Power Short-Circuit EMG	When short-circuiting of the SW power supply with GND has lasted for 0.5 second or more, [E:07] is identified, all the motors are stopped and the power is turned off.	<ol style="list-style-type: none"> The SW 5 V power supply circuit is shorted with GND. The SW 12 V power supply circuit is shorted with GND.
E08: DD Initialized (Absolute Position Sensor) EMG	When DD tilting does not complete in 4 seconds, [E:08] is identified, the tilt motor is stopped and the power is turned off.	<ol style="list-style-type: none"> The absolute value sensor is defective. (The soldered parts have separated.) The pull-up resistor at the absolute sensor output is defective. (The soldered parts have separated.) Contact failure or soldering failure of the pins of the connector (board-to-board) to the absolute value sensor. The absolute value sensor data is not sent to the System Controller CPU.
E09: DD FG EMG	When the DD FG pulse is not generated within 2.5 seconds, [E:09] is identified, the tilt motor is stopped and the power is turned off.	<ol style="list-style-type: none"> The FG sensor is defective. (The soldered parts have separated.) The pull-up resistor at the FG sensor output is defective. (The soldered parts have separated.) Contact failure or soldering failure of the pins of the connector (board-to-board) to the FG sensor. The power to the sensor is not supplied. (Connection failure/soldering failure) The FG pulse is not sent to the System Controller CPU. The tilt motor is defective. (The soldered parts have separated.) The drive power to the tilt motor is not supplied. (Connection failure/soldering failure) The tilt motor drive MDA - IC is defective. Auto-recovery of the DD tilting cannot take place due to overrun.
E0A: Supply Reel Pulse EMG	When the supply reel pulse has not been generated for more than 10 seconds in the capstan rotating mode, [E:0A] is identified and the cassette is ejected (but the power is not turned off). However, note that the reel EMG is not detected in the SLOW/STILL mode.	<ol style="list-style-type: none"> The supply reel pulse is not generated in the FWD transport mode (PLAY/FWD SEARCH/FF, etc.) because; <ol style="list-style-type: none"> PLAY/FWD or SEARCH/FF is started while the tape in the inserted cassette is cut in the middle; A mechanical factor caused tape slack inside and outside the supply reel side of the cassette shell. In this case, the supply reel will not rotate until the tape slack is removed by the FWD transport, so the pulse is not generated until then; The FG pulse output from the supply reel sensor is absent. The take-up reel pulse is not generated in the REV transport mode (REV SEARCH/REW, etc.). <ol style="list-style-type: none"> REV SEARCH/REW is started when the tape in the inserted cassette has been cut in the middle; A mechanical factor caused tape slack inside and outside the take-up reel side of the cassette shell. In this case, the supply reel will not rotate until the tape slack is removed by the REV transport, so the pulse will not be generated until that time; The FG pulse output from the take-up reel sensor is absent. The power to a reel sensor is not supplied.
EC1 or EU1: Head clog warning	<p>Presupposing the presence of the control pulse output in the PLAY mode, when the value obtained by mixing the two V.FM output channels (without regard to the A.FM output) has remained below a certain threshold level for more than 10 seconds, [E:C1] or [E:U1] is identified and recorded in the emergency history. During the period in which a head clog is detected, the FDP and OSD repeat the “3-second warning display” and “7-second noise picture display” alternately.</p> <p>EMG code : “E:C1” or “E:U1” / FDP : “U:01” / OSD : “Try cleaning tape.” or “Use cleaning cassette.”</p> <p>The head clog warning is reset when the above-mentioned threshold has been exceeded for more than 2 seconds or the mode is changed to another mode than PLAY.</p>	

Table 1-7-3a

1.7.4 EMG detail information <1>

The status (electrical operation mode) of the VCR and the status (mechanism operation mode/sensor information) of the mechanism in the latest EMG can be confirmed based on the figure in EMG detail information <1> .

[FDP/OSD display]

* 1 : * 2 : 34

- * 1 : Deck operation mode at the moment of EMG
- * 2 : Mechanism operation mode at the moment of EMG
- 3— : Mechanism sensor information at the moment of EMG
- 4 : Mechanism mode position at the moment of EMG

Note:

- For EMG detailed information <1>, the content of the code that is shown on the FDP (or OSD) differs depending on the parts number of the system control microprocessor (IC3001) of the VCR. The system control microprocessor parts number starts with two letters, refer these to the corresponding table.

* 1 : Deck operation mode

[Common table of MN*, HD* and M3*]

Display		Deck operation mode
MN*/M3*	HD*	
00	-	Mechanism being initialized
01	00	STOP with pinch roller pressure off (or tape present with P.OFF)
02	01	STOP with pinch roller pressure on
03	-	POWER OFF as a result of EMG
04	04	PLAY
0C	0E	REC
10	11	Cassette ejected
20	22	FF
21	-	Tape fully loaded, START sensor ON, short FF
22	-	Cassette identification FWD SEARCH before transition to FF (SP x7-speed)
24	26	FWD SEARCH (variable speed) including x2-speed
2C	2E	INSERT REC
40	43	REW
42	-	Cassette identification REV SEARCH before transition to REW (SP x7-speed)
44	47	REV SEARCH (variable speed)
4C	4C	AUDIO DUB
6C	6E	INSERT REC (VIDEO + AUDIO)
84	84	FWD STILL / SLOW
85	85	REV STILL / SLOW
8C	8F	REC PAUSE
8D	-	Back spacing
8E	-	Forward spacing (FWD transport mode with BEST function)
AC	AF	INSERT REC PAUSE
AD	-	INSERT REC back spacing
CC	CD	AUDIO DUB PAUSE
CD	-	AUDIO DUB back spacing
EC	EF	INSERT REC (VIDEO + AUDIO) PAUSE
ED	-	INSERT REC (VIDEO + AUDIO) back spacing

* 2 : Mechanism operation mode

[Common table of MN* and M3*]

Display		Mechanism operation mode
MN*	M3*	
00	00	Command standby (Status without executing command)
02	02	POWER OFF by EMG occurrence
04	04	Moving to the adjacent position in the LOAD direction
06	06	Moving to the adjacent position in the UNLOAD direction
08	08	Cassette ejection being executed / Cassette housing ejection being executed
-	0A	Mode transition to STOP with cassette ejection end
0A	0C	Cassette insertion being executed
0C	0E	Tape being loaded
0E	10	Tape being unloaded
10	12	Mode transition to STOP with pinch roller compression ON
12	14	Mode transition to STOP with pinch roller compression OFF
14	16	Mode transition to STOP with pinch roller compression OFF as a result of POWER OFF
16	18	Mode transition to STOP with pinch roller compression ON as a result of POWER ON
18	1A	Mode transition to PLAY
1A	1C	Mode transition to FWD SEARCH
1C	1E	Mode transition to REC
1E	20	Mode transition to FWD STILL / SLOW
20	22	Mode transition to REV STILL / SLOW
22	24	Mode transition to REV SEARCH
24	26	Mode transition from FF / REW to STOP
26	28	Mode transition to FF
28	2A	Mode transition to REW
2A	2C	4 sec. of REV as a result of END sensor going ON during loading
2C	2E	Short FF / REV as a result of END sensor going ON during unloading
2E	30	Mechanism position being corrected due to overrun
80	80	Mechanism in initial position (Dummy command)

[Table of HD]

Display	Mechanism operation mode
00	STOP with pinch roller pressure off
01	STOP with pinch roller pressure on
02	U/L STOP (or tape being loaded)
04	PLAY
05	PLAY (x1-speed playback using JOG)
0E	REC
11	Cassette ejected
22	FF
26	FWD SEARCH (variable speed) including x2-speed
2E	INSERT REC
43	REW
47	REV SEARCH
4C	AUDIO DUB
6E	INSERT REC (VIDEO + AUDIO)
84	FWD STILL/SLOW
85	REV STILL/SLOW
8F	REC PAUSE
AF	INSERT REC PAUSE
C7	REV SEARCH (x1-speed reverse playback using JOG)
CD	AUDIO DUB PAUSE
EF	INSERT REC (VIDEO + AUDIO) PAUSE
F0	Mechanism being initialized
F1	POWER OFF as a result of EMG
F2	Cassette being inserted
F3	Cassette being ejected
F4	Transition from STOP with pinch roller pressure on to STOP with pinch roller pressure off
F5	Transition from STOP with pinch roller pressure on to PLAY
F6	Transition from STOP with pinch roller pressure on to REC
F7	Cassette type detection SEARCH before FF/REW is being executed
F8	Tape being unloaded
F9	Transition from STOP with pinch roller pressure off to STOP with pinch roller pressure on
FA	Transition from STOP with pinch roller pressure off to FF/REW
FB	Transition from STOP with pinch roller pressure off to REC.P (T.REC,etc.)
FC	Transition from STOP with pinch roller pressure off to cassette type detection SEARCH
FD	Short REV being executed after END sensor on during unloading
FE	Tension loosening being executed after tape loading (STOP with pinch roller pressure on)

3- : Mechanism sensor information
[Common table of MN*, HD* and M3*]

Display	Mechanism sensor information				
	MN* / HD* S-VHS SW	M3* CASS SW	REC safety SW	Start sensor	End sensor
0-	VHS	Cassette insertion	Tab broken	ON	ON
1-	VHS	Cassette insertion	Tab broken	ON	OFF
2-	VHS	Cassette insertion	Tab broken	OFF	ON
3-	VHS	Cassette insertion	Tab broken	OFF	OFF
4-	VHS	Cassette insertion	Tab present	ON	ON
5-	VHS	Cassette insertion	Tab present	ON	OFF
6-	VHS	Cassette insertion	Tab present	OFF	ON
7-	VHS	Cassette insertion	Tab present	OFF	OFF
8-	S-VHS	Cassette ejection	Tab broken	ON	ON
9-	S-VHS	Cassette ejection	Tab broken	ON	OFF
A-	S-VHS	Cassette ejection	Tab broken	OFF	ON
B-	S-VHS	Cassette ejection	Tab broken	OFF	OFF
C-	S-VHS	Cassette ejection	Tab present	ON	ON
D-	S-VHS	Cassette ejection	Tab present	ON	OFF
E-	S-VHS	Cassette ejection	Tab present	OFF	ON
F-	S-VHS	Cassette ejection	Tab present	OFF	OFF

-4 : Mechanism mode position
[Common table of MN*, HD* and M3*]

Display			Mechanism mode position
MN*	HD*	M3*	
-0	-7	-	Initial value
-1	-0	-	EJECT position
-	-	-0	EJECT position (Cassette housing drive mode)
-2	-7	-	Housing operating
-	-	-1	Between EJECT and U / L STOP
-3	-1	-2	U / L STOP position
-	-	-3	Guide arm drive position
-4	-7	-4	Tape being loaded / unloaded (When the pole base is located on the front side of the position just beside the drum)
-5	-2	-5	Tape being loaded / unloaded (When the pole base is located on the rear side of the position just beside the drum)
-6	-7	-6	Pole base compressed position
-7	-3	-F	FF / REW position
-8	-7	-F	Between FF / REW and STOP with pinch roller compression ON
-9	-4	-F	STOP with pinch roller compression OFF
-A	-7	-E	Between STOP with pinch roller compression OFF and REV
-B	-5	-	REV (REV STILL / SLOW) position
-	-	-D	REV position
-	-	-C	Between REV and REV STILL / SLOW
-	-	-B	REV STILL / SLOW position
-C	-7	-	Between REV and FWD
-	-	-A	Between REV STILL / SLOW and FWD STILL / SLOW
-D	-6	-	FWD (FWD STILL / SLOW) position
-	-	-9	FWD STILL / SLOW position
-E	-7	-	Between FWD and PLAY
-	-	-8	Between FWD STILL / SLOW and PLAY
-F	-6	-7	PLAY position

Note:

- In the case of the "HD" microprocessor, as the display is always "-7" at any intermediate position between modes, the position of transitory EMG may sometimes not be located.

1.7.5 EMG detail information <2>

The type of the cassette tape and the cassette tape winding position can be confirmed based on the figure in EMG detail information <2> .

[FDP/OSD display]

*5 : *6 : *7

- *5 : Type of the cassette tape in use <1>
- *6 : Winding position of the cassette tape in use
- *7 : Type of the cassette tape in use <2> (Winding area)

Note:

- EMG detail information <2> is the reference information stored using the remaining tape detection function of the cassette tape. As a result, it may not identify cassette correctly when a special cassette tape is used or when the tape has variable thickness.

***5 : Cassette tape type <1>**

Display	Cassette tape type <1>
00	Cassette type not identified
16	Large reel/small reel (T-0 to T-15/T-130 to T-210) not classified
82	Small reel, thick tape (T-120) identified/thin tape (T-140) identified
84	Large reel (T-0 to T-60) identified
92	Small reel, thick tape (T-130) identified/thin tape (T-160 to T-210) identified
93	Small reel, thick tape/C cassette (T-0 to T-100/C cassette) not classified
C3	Small reel, thick tape/C cassette (T-0 to T-100/C cassette) being classified
D3	Small reel, thick tape/C cassette (T-0 to T-100/C cassette) being classified
E1	C cassette, thick tape (TC-10 to TC-20) identified
E2	Small reel, thick tape (T-0 to T-100) identified
E9	C cassette, thin tape (TC-30 to TC-40) identified
F1	C cassette, thick tape/thin tape (TC-10 to TC-40) not classified

Notes:

- Cassette tape type <1> is identified a few times during mode transition and the identification count is variable depending on the cassette tape type. If an EMG occurs in the middle of identification, the cassette tape type may not be able to be identified.
- If other value than those listed in the above table is displayed, the cassette tape type is not identified.

***6 : Cassette tape winding position**

The cassette tape winding position at the moment of EMG is displayed by dividing the entire tape (from the beginning to the end) in 22 sections using a hex number from "00" to "15".

- "00" : End of winding
- "15" : Beginning of winding
- "FF or --" : Tape position not identified

***7 : Cassette tape type <2> (Winding area)**

Display	Cassette tape type <2>
00	Cassette type not identified
07	Small reel, thick tape T-5
08 - 0E	C cassette, thick tape TC-10
09 - 15	C cassette, thick tape TC-20P
0A - 0B	Small reel, thick tape T-20
0A - 16	C cassette, thin tape TC-30
0A - 16	C cassette, thin tape TC-40
0D - 0F	Small reel, thick tape T-40
11 - 14	Small reel, thick tape T-60
15 - 18	Small reel, thick tape T-80 / DF-160
17 - 1A	Small reel, thick tape T-90 / DF-180
19 - 1D	Small reel, thick tape T-100
1D - 21	Small reel, thick tape T-120 / DF-240
1E - 1F	Small reel, thin tape T-140
1F - 23	Small reel, thick tape T-130
21 - 23	Small reel, thin tape T-160
21 - 23	Small reel, thin tape T-168
22 - 24	Small reel, thick tape DF-300
22 - 24	Small reel, thin tape T-180 / DF-360
22 - 24	Small reel, thin tape T-210 / DF-420
22 - 23	Large reel T-5
23 - 24	Large reel T-10
25 - 26	Large reel T-20
27 - 29	Large reel T-30
29 - 2B	Large reel T-40
2D - 2F	Large reel T-60

Note:

- The values of cassette tape type <2> in the above table are typical values with representative cassette tapes.

SECTION 2 MECHANISM ADJUSTMENT

2.1 BEFORE STARTING REPAIR AND ADJUSTMENT

2.1.1 Precautions

- (1) Unplug the power cable of the main unit before using your soldering iron.
- (2) Take care not to cause any damage to the conductor wires when plugging and unplugging the connectors.
- (3) Do not randomly handle the parts without identifying where the trouble is.
- (4) Exercise enough care not to damage the lugs, etc. during the repair work.
- (5) When installing the front panel assembly, be sure to hook the lug on the back side of the cassette door to the door opener of the cassette holder. If this operation is neglected it will not be possible to remove the cassette when ejecting because the housing door cannot be opened.

2.1.2 Checking for Proper Mechanical Operations

Enter the mechanism service mode when you want to operate the mechanism when no cassette is loaded. (See 1.5 MECHANISM SERVICE MODE.)

2.1.3 Manually Removing the Cassette Tape

1. In case of electrical failures

If you cannot remove the cassette tape which is loaded because of any electrical failure, manually remove it by taking the following steps.

- (1) Unplug the power cable and remove the top cover, bracket and front panel assembly. (See 1.3 DISASSEMBLY/ASSEMBLY METHOD.)
- (2) Unload the cassette by manually turning the loading motor of the mechanism assembly toward the front. In doing so, hold the tape by the hand to keep the slack away from any grease. (See Fig.2-1-3a.)
- (3) Bring the pole base assembly (supply or take-up side) to a pause when it reaches the position where it is hidden behind the cassette tape.
- (4) Move the top guide toward the drum while holding down the lug **(A)** of the bracket retaining the top guide. Likewise hold part **(B)** down and remove the top guide. Section **(C)** of the top guide is then brought under the cassette lid. Then remove the top guide by pressing the whole cassette tape down. (See Fig.2-1-3b.)
- (5) Remove the cassette tape by holding both the slackened tape and the cassette lid.
- (6) Take up the slack of the tape into the cassette. This completes removal of the cassette tape.

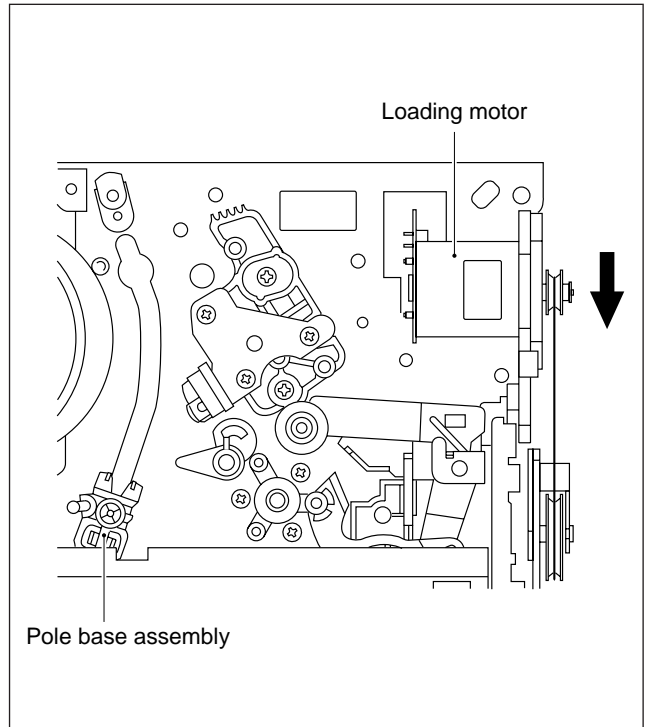

Fig. 2-1-3a

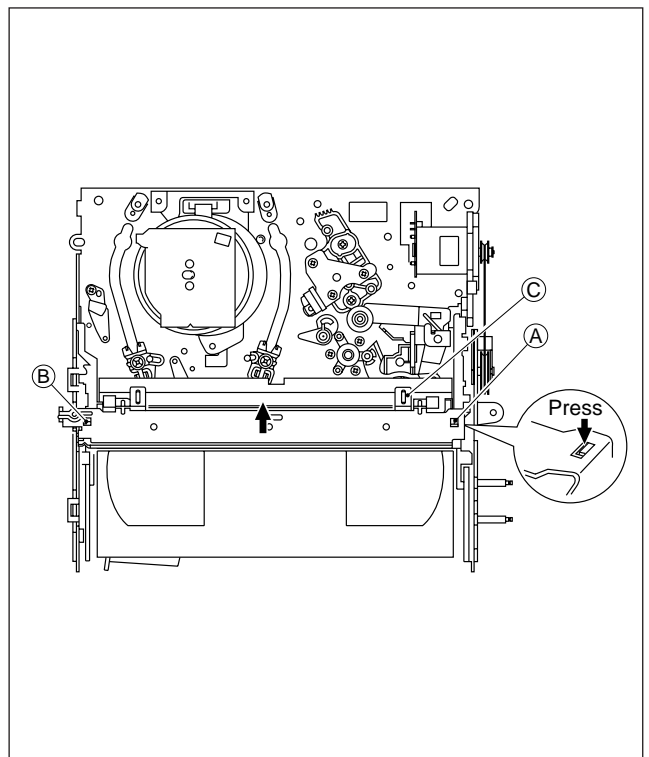

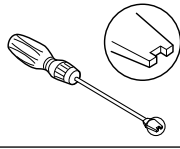

Fig. 2-1-3b

2. In case of mechanical failure

If you cannot remove the cassette tape which is loaded because of any mechanical failure, manually remove it by taking the following steps.

- (1) Unplug the power cable and remove the top cover, front panel assembly and others so that the mechanism assembly is visible. (See 1.3 DISASSEMBLY/ASSEMBLY METHOD.)
- (2) While keeping the tension arm assembly of the mechanism assembly free from tension, pull the tape on the pole base assembly (supply or take-up side) out of the guide roller. (See Fig.2-1-3c.)
- (3) Take the spring of the pinch roller arm assembly off the hook of the press lever assembly, and detach it from the tape. (See Fig.2-1-3d.)
- (4) In the same way as in the electrical failure instructions in 2.1.3-1(4), remove the top guide.
- (5) Raise the cassette tape cover. By keeping it in that position, draw out the cassette tape case from the cassette holder and take out the tape.
- (6) By hanging the pinch roller arm assembly spring back on the hook, take up the slack of the tape into the cassette.

2.1.4 Jigs and Tools Required for Adjustment

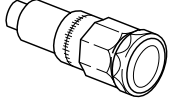
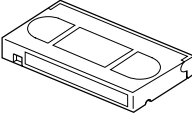
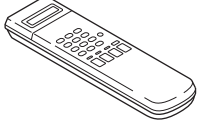
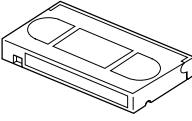
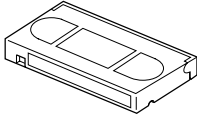
Roller driver PTU94002	A/C head positioning tool PTU94010	Torque gauge PUJ48075-2
		
Back tension cassette gauge PUJ48076-2	Jig RCU PTU94023B	
		
Alignment tape (SP, stairstep, PAL) MHPE	Alignment tape (LP, stairstep, PAL) MHPE-L	
		

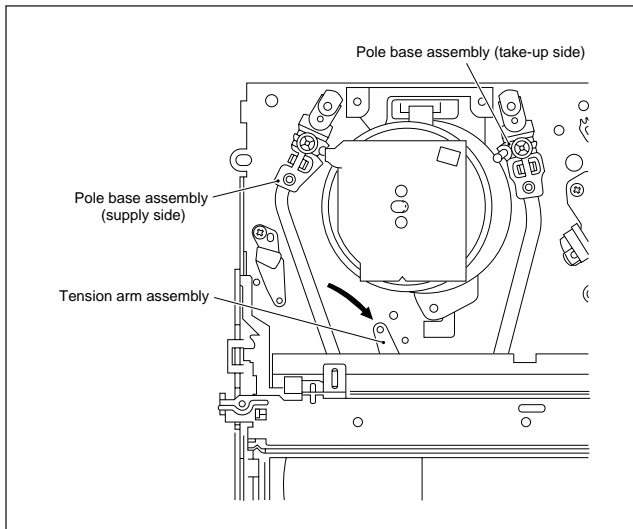

Fig. 2-1-3c

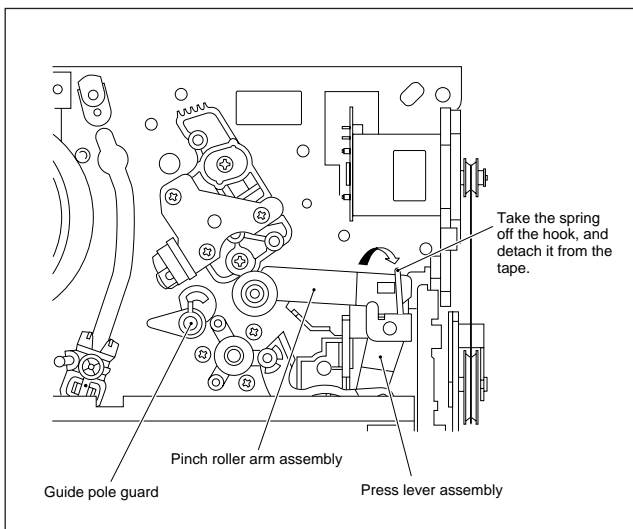

Fig. 2-1-3d

2.1.5 Maintenance and Inspection

1. Location of major mechanical parts

In this chapter, the two mechanism speeds are described by comparing the speeds of the standard type and the high-speed FF/REW type.

It is possible to distinguish between these two types of mechanism by the diameters of their capstan pulleys.

The capstan pulley diameter for the standard type is approx. 32 mm.

The capstan pulley diameter for the high-speed FF/REW type is approx. 43 mm.

For information on the different parts used in the two mechanism types, please refer to the "Replacement of major parts".

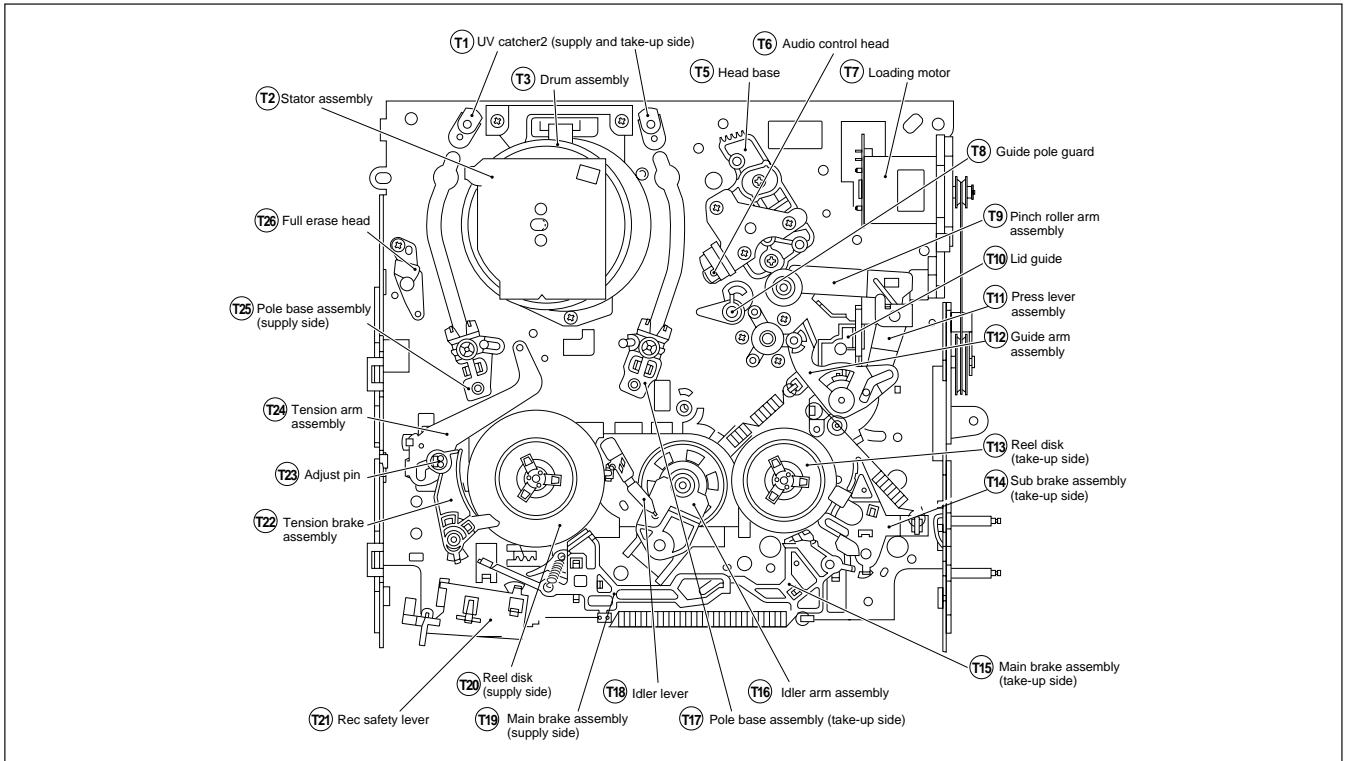

Fig. 2-1-5a Mechanism assembly top side

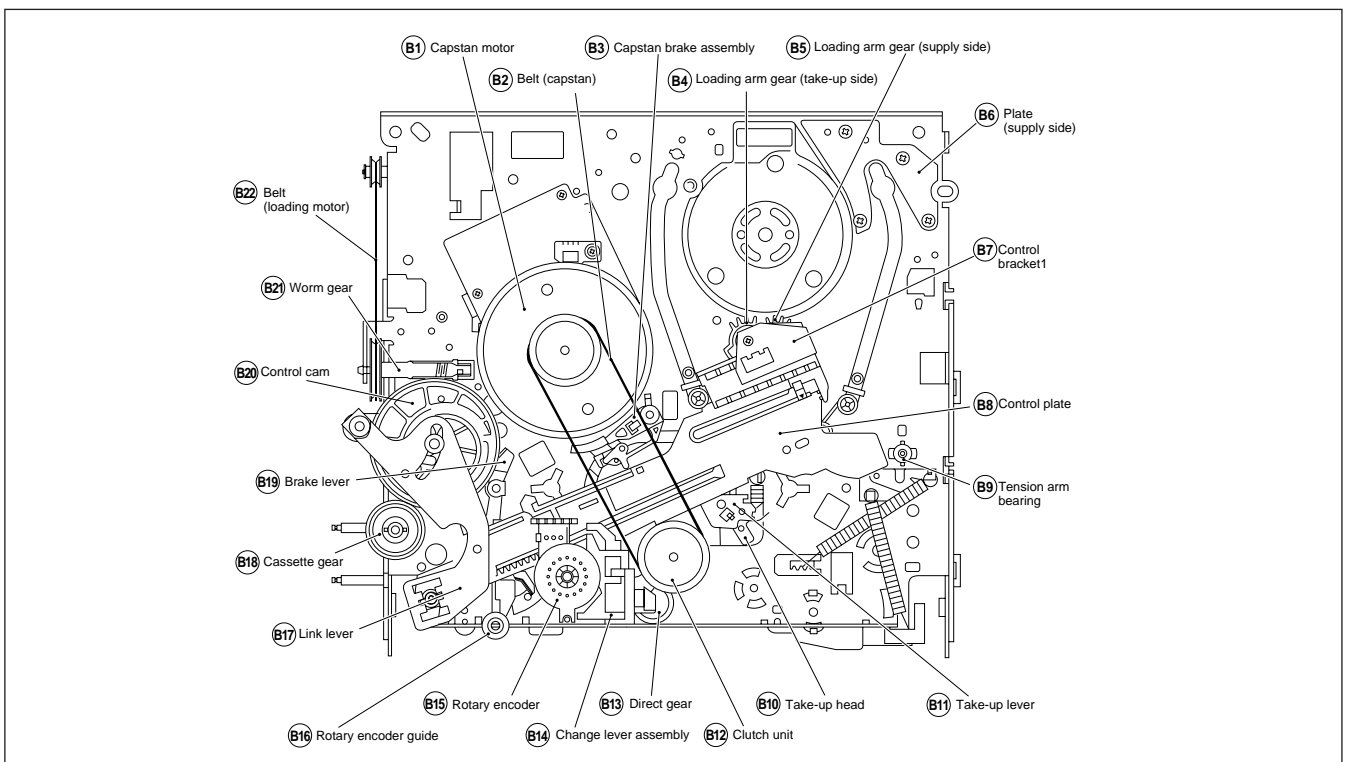

Fig. 2-1-5b Mechanism assembly bottom side

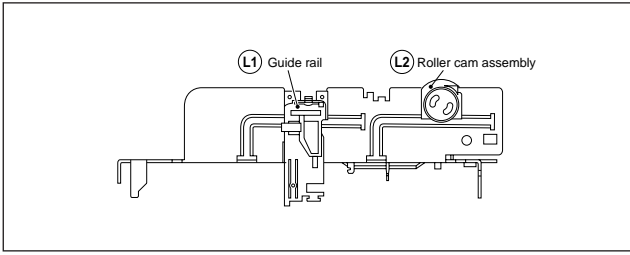

Fig. 2-1-5c Mechanism assembly left side

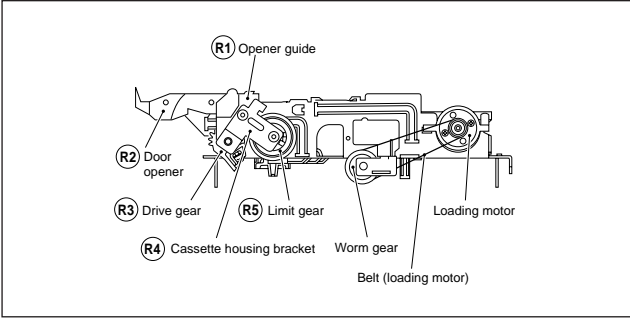

Fig. 2-1-5d Mechanism assembly right side

2. Cleaning

Regular cleaning of the transport system parts is desirable but practically impossible. So make it a rule to carry out cleaning of the tape transport system whenever the machine is serviced.

When the video head, tape guide and/or brush get soiled, the playback picture may appear inferior or at worst disappear, resulting in possible tape damage.

- (1) When cleaning the upper drum (especially the video head), soak a piece of closely woven cloth or Kimu-wipe with alcohol and while holding the cloth onto the upper drum by the fingers, turn the upper drum counterclockwise.

Note:

- **Absolutely avoid sweeping the upper drum vertically as this will cause damage to the video head.**

- (2) To clean the parts of the tape transport system other than the upper drum, use a piece of closely woven cloth or a cotton swab soaked with alcohol.
- (3) After cleaning, make sure that the cleaned parts are completely dry before using the video tape.

3. Lubrication

With no need for periodical lubrication, you have only to lubricate new parts after replacement. If any oil or grease on contact parts is soiled, wipe it off and newly lubricate the parts.

Note:

- **See the “mechanism assembly” diagram of the parts list for the lubricating or greasing spots, and for the types of oil or grease to be used.**

4. Suggested servicing schedule for main components

The following table indicates the suggested period for such service measures as cleaning, lubrication and replacement. In practice, the indicated periods will vary widely according to environmental and usage conditions. However, the indicated components should be inspected when a set is brought for service and the maintenance work performed if necessary. Also note that rubber parts may deform in time, even if the set is not used.

System	Parts Name	Operation Hours	
		~1000H	~2000H
Tape transport	Upper drum assembly	★○	○
	A/C head	★○	★○
	Lower drum assembly	★	★○
	Pinch roller arm assembly	★	★
	Full erase head	★	★
	Tension arm assembly	★	★
	Capstan motor (Shaft)	★	★
	Guide arm assembly	★	★
Drive	Capstan motor		○
	Capstan brake assembly		○
	Main brake assembly		○
	Belt (Capstan)	○	○
	Belt (Loading motor)		○
	Loading motor		○
	Clutch unit		○
	Worm gear		○
	Control plate		○
Other	Brush	★○	★○
	Tension brake assembly	○	○
	Rotary encoder		○

★ : Cleaning

○ : Inspection or Replacement if necessary

Table 2-1-5a

5. Disassembling procedure table

The following table indicates the order in which parts are removed for replacement. To replace parts, remove them in the order of 1 to 18 as shown in the table. To install them, reverse the removal sequence.

The symbols and numbers preceding the individual part names represent the numbers in the “Location of major mechanical parts” table. Also, the “T”, “B”, and “T/B” on the right of each part name shows that the particular part is removed from the front, from the back, and from both sides of the mechanism, respectively.

Symbols and numbers			L1	L2	R4	R1	-	-	R3	-	T9	T12	T11	T1	B15	B12	B14	B13	-	B17	B21	B7	B8	B5	B4	B11	T14	T15	T13	T22	T24	T18	B19		
Symbols and numbers	Removal parts (Reference items) Replacement parts	Front (T)/Back (B) of mechanism Number of removal steps	Guide rail	Roller cam assembly	Cassette housing bracket	Opener guide	Relay gear	Cassette holder assembly	Drive gear	Drive arm	Pinch roller arm assembly	Guide arm assembly	Press lever assembly	UV catcher2	Rotary encoder	Clutch unit	Change lever assembly	Direct gear	Coupling gear	Link lever	Worm gear	Control bracket1	Control plate	Loading arm gear (supply side)	Loading arm gear (take-up side)	Take-up lever	Sub brake assembly (take-up side)	Main brake assembly (take-up side)	Reel disk (take-up side)	Tension brake assembly	Tension arm assembly	Idler lever	Brake lever (*1)		
			L1	2.2.3 Guide rail	T	1																													
L2	2.2.3 Roller cam assembly	T	1																																
R4	2.2.3 Cassette housing bracket	T	1																																
R1	2.2.3 Opener guide	T	2		1																														
R2	2.2.3 Door opener	T	3		1	2																													
-	2.2.3 Relay gear	T	3		1	2																													
R5	2.2.3 Limit gear	T	3		1	2																													
-	2.2.3 Cassette holder assembly	T	6	1	2	3	4	5																											
R3	2.2.3 Drive gear	T	4		1	2	3																												
-	2.2.3 Drive arm	T	8	1	2	3	4	5	6	7																									
T9	2.2.4 Pinch roller arm assembly	T	1																																
T12	2.2.5 Guide arm assembly	T	1																																
T11	2.2.5 Press lever assembly	T	3								1	2																							
T6	2.2.6 A/C head	T	1																																
T7	2.2.7 Loading motor	T	1																																
B1	2.2.8 Capstan motor	T/B	1																																
T1	2.2.9 UV catcher2	T	1																																
T17	2.2.9 Pole base assembly (take-up side)	T/B	2											1																					
T25	2.2.9 Pole base assembly (supply side)	T/B	2											1																					
B15	2.2.10 Rotary encoder	B	1																																
B12	2.2.11 Clutch unit	B	1																																
B14	2.2.12 Change lever assembly	B	3												1	2																			
B13	2.2.12 Direct gear	B	4												1	2	3																		
-	2.2.12 Coupling gear	B	5												1	2	3	4																	
-	2.2.12 Clutch gear	B	6												1	2	3	4	5																
B17	2.2.13 Link lever	B	1																																
B18	2.2.14 Cassette gear	B	2																		1														
B20	2.2.14 Control cam	B	2																		1														
B21	2.2.14 Worm gear	B	1																																
T10	- Lid guide	T/B	5								1	2	3									4													
B7	2.2.15 Control bracket1	B	1																																
B8	2.2.15 Control plate	B	6												1	2	3				4		5												
B5	2.2.16 Loading arm gear (supply side)	B	7												1	2	3				4	5	6												
B4	2.2.16 Loading arm gear (take-up side)	B	8												1	2	3				4	5	6	7											
-	2.2.16 Loading arm gear shaft	B	9												1	2	3				4	5	6	7	8										
B11	2.2.17 Take-up lever	T/B	7												1	2	3				4	5	6												
B10	2.2.17 Take-up head	T/B	8												1	2	3				4	5	6				7								
-	2.2.17 Control plate guide	T/B	8												1	2	3				4	5	6				7								
B3	2.2.18 Capstan brake assembly	T/B	7												1	2	3				4	5	6												
T14	2.2.19 Sub brake assembly (take-up side)	T/B	15	1	2	3	4	5	6	7	8				9	10	11				12	13	14												
T15	2.2.20 Main brake assembly (take-up side)	T/B	16	1	2	3	4	5	6	7	8				9	10	11				12	13	14				15								
T19	2.2.20 Main brake assembly (supply side)	T/B	9	1	2	3	4	5	6	7	8																								
T13	2.2.20 Reel disk (take-up side)	T/B	16	1	2	3	4	5	6	7	8				9	10	11				12	13	14				15								
T22	2.2.21 Tension brake assembly	T/B	9	1	2	3	4	5	6	7	8																								
T20	2.2.21 Reel disk (supply side)	T/B	10	1	2	3	4	5	6	7	8																				9				
T24	2.2.21 Tension arm assembly	T/B	10	1	2	3	4	5	6	7	8																								
B9	2.2.21 Tension arm bearing	T/B	10	1	2	3	4	5	6	7	8																								
T18	2.2.22 Idler lever	T/B	17	1	2	3	4	5	6	7	8				9	10	11				12	13	14						15	16					
T16	2.2.22 Idler arm assembly	T/B	18	1	2	3	4	5	6	7	8				9	10	11				12	13	14						15	16	17				
B19	- Brake lever (*1)	T/B	18	1	2	3	4	5	6	7	8				9	10	11				12	13	14				15	16	17						
B16	- Rotary encoder guide	T/B	19	1	2	3	4	5	6	7	8				9	10	11				12	13	14				15	16	17					18	

Table 2-1-5b

Note:

- The parts with marked (*) have different types of mechanisms (standard type or high-speed FF/REW type).
 - *1: Uses the standard type mechanism only.
 - *2: Uses the high-speed FF/REW type mechanism only.

2.2 REPLACEMENT OF MAJOR PARTS

2.2.1 Before Starting Disassembling (Phase matching between mechanical parts)

The mechanism of this unit is closely linked with the rotary encoder and system controller circuits.

Since the system controller detects the status of mechanical operation in response to phases of the rotary encoder (internal switch positions), the mechanism may not operate properly unless such parts as the rotary encoder, control plate, loading arm gear, control cam, cassette gear, limit gear, relay gear and drive gear are installed in their correct positions.

Especially, this model is not provided with any cassette housing assembly, so that cassette loading and unloading must be accomplished by operation of the cassette holder assembly. The latter is in turn driven by such parts as the drive gear, relay gear and limit gear. Exercise enough care, therefore, to have the phases of all this gear matching one another. (For information on phase matching of the mechanism, see the instructions on how to install individual parts.)

This unit is provided with a mechanism assembly mode. It is therefore necessary to enter this mode for assembling and disassembling procedures.

This mode is usually not in use, manually set it when it is required.

2.2.2 How to Set the Mechanism Assembling Mode

Remove the mechanism assembly and place it bottom side up. (See SECTION 1 DISASSEMBLY.) Turn the worm gear toward the front so that the guide hole of the control cam is brought into alignment with the hole at the mechanism assembly chassis. This position renders the mechanism assembling mode operational. Make sure that the control plate is located in alignment with the mark E. (See Fig.2-2-2a.)

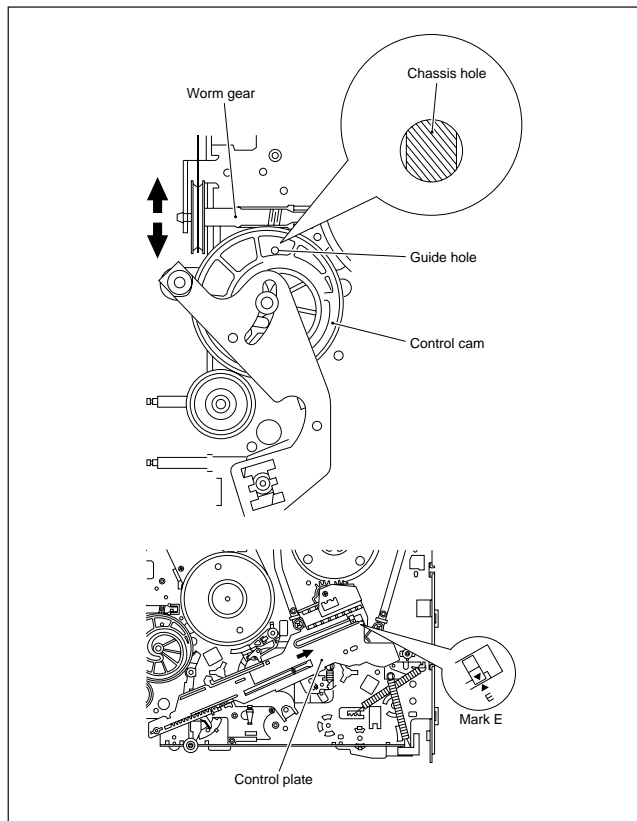

Fig. 2-2-2a

2.2.3 Cassette Holder Assembly

1. How to remove

(1) Remove the guide rail and roller cam assembly. (See Fig.2-2-3a.)

(3 lugs on the guide rail and one lug on the roller cam assembly)

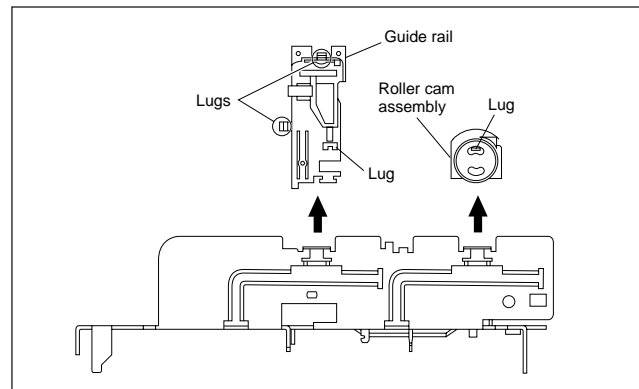

Fig. 2-2-3a

(2) Remove the two slit washers and remove the cassette housing bracket. (See Fig.2-2-3b.)

(3) Remove the opener guide, spring(A), door opener, relay gear and limit gear. (See Fig.2-2-3b.)

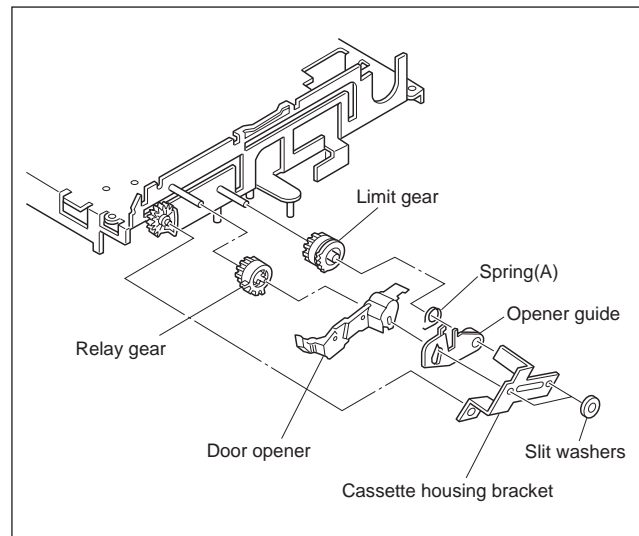

Fig. 2-2-3b

(4) While swinging the lock levers (R) and (L) of the cassette holder assembly toward the front, slide the cassette holder assembly until its legs come to where the guide rail and the roller cam assembly have been removed (so that the drive arm is upright). (See Fig.2-2-3c.)

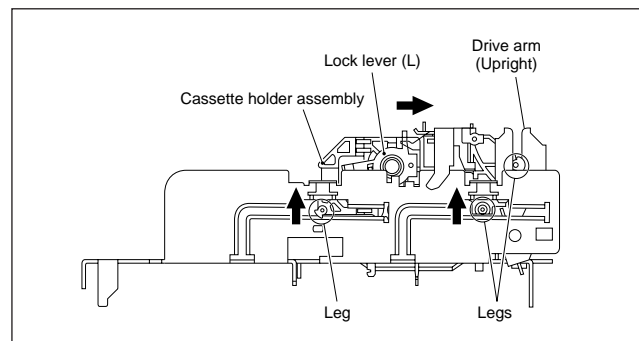

Fig. 2-2-3c

- (5) While holding the left side of the cassette holder, lift the cassette holder assembly so that the three legs on the left side are all released. Then pull the legs (A) and (B) on the right side out of the rail and also pull up the leg (C). (See Fig.2-2-3d and Fig.2-2-3e.)
- (6) Draw out the drive gear, and remove the drive arm.

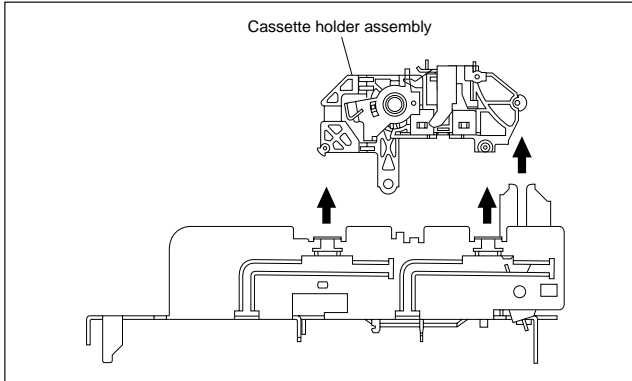

Fig. 2-2-3d

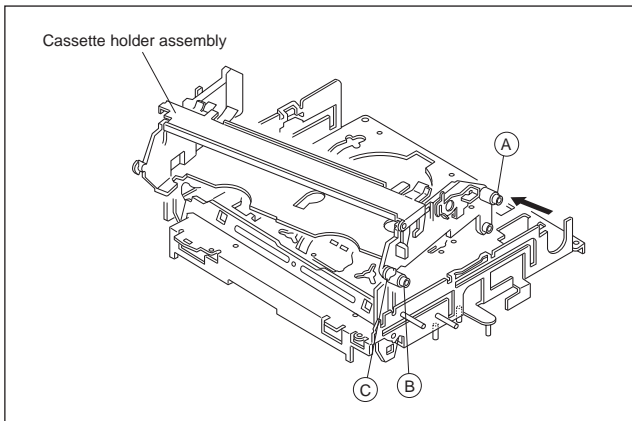

Fig. 2-2-3e

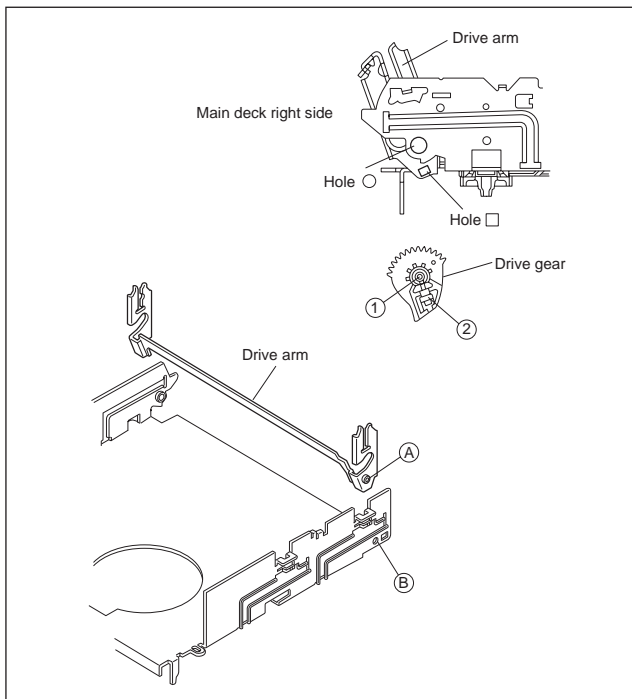

Fig. 2-2-3f

2. How to install (Phase matching)

- (1) Insert the section (A) of the drive arm into the section (B) of the main deck.
- (2) Insert the section (1) of the drive gear into the round hole, and the section (2) into the square hole on the drive arm. (See Fig.2-2-3f.)
- (3) Hold the drive arm upright and fit the leg (C) on the right side of the cassette holder assembly into the groove. (See Fig.2-2-3g.)
- (4) While swinging the lock lever (R) of the cassette holder assembly toward the front, put the legs (A) and (B) into the rail. (See Fig.2-2-3g.)
- (5) Drop the three legs on the left side of the cassette holder assembly into the groove at one time. (See Fig.2-2-3h.)
- (6) Slide the whole cassette holder assembly toward the front to bring it to the eject end position.
- (7) Install the limit gear so that the notch on the outer circumference of the limit gear is brought into alignment with the guide hole on the main deck. (See Fig.2-2-3i.)
- (8) Install so that the notch on the periphery of the relay gear is aligned with the notch of the main deck and that hole A of the relay gear is aligned with the hole A of the limit gear and that hole B of the relay gear is aligned with the hole B of the drive gear. (See Fig.2-2-3i.)
- (9) Install the door opener, opener guide, spring(A) and cassette housing bracket and fasten the two slit washers.

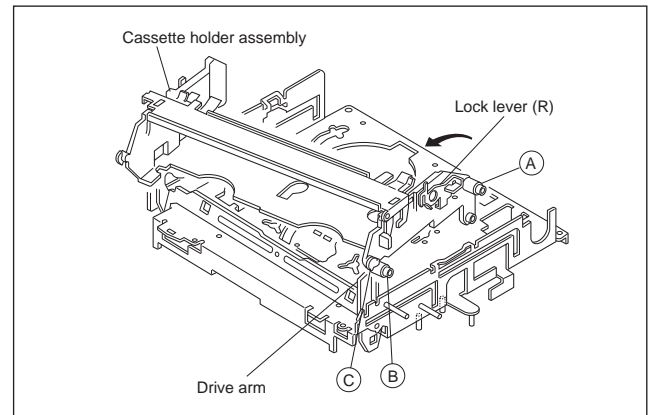

Fig. 2-2-3g

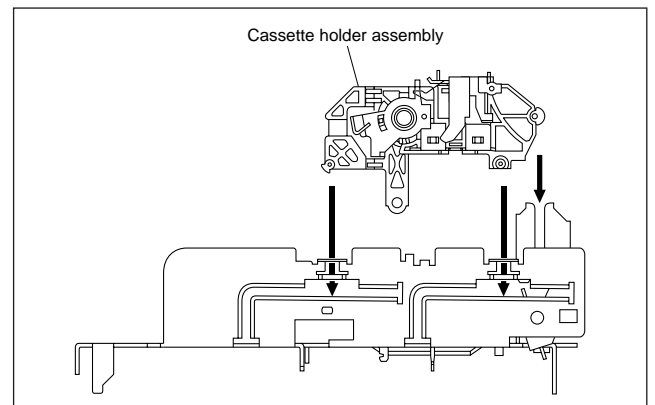

Fig. 2-2-3h

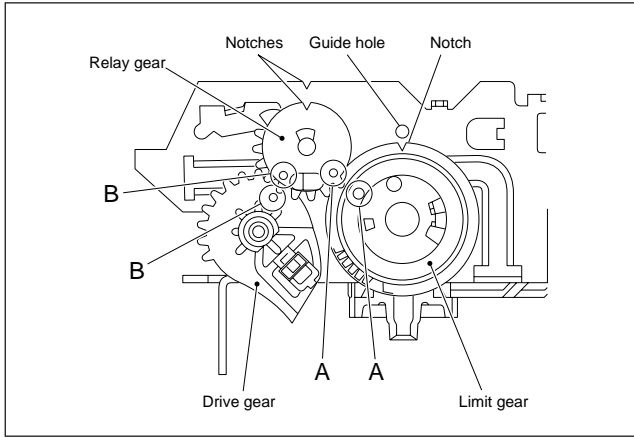

Fig. 2-2-3i

2.2.4 Pinch Roller Arm Assembly

1. How to remove

- (1) Remove the spring from the hook of the press lever assembly.
- (2) Remove the slit washer and remove the pinch roller seat 2. (See Fig.2-2-4a.)
- (3) Remove the pinch roller arm assembly by pulling it up.

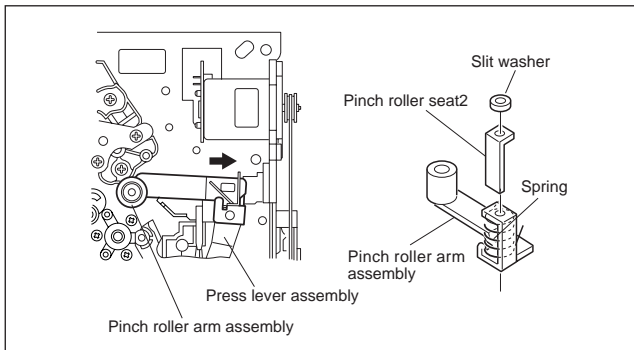

Fig. 2-2-4a

2.2.5 Guide Arm Assembly and Press Lever Assembly

1. How to remove

- (1) Remove the spring and expand the lug of the lid guide in the arrow-indicated direction. Then remove the guide arm assembly by pulling it up.
- (2) Remove the press lever assembly by pulling it up. (See Fig.2-2-5a.)

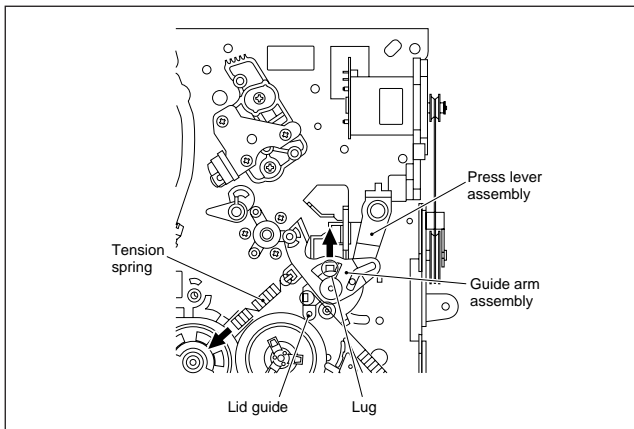

Fig. 2-2-5a

2.2.6 Audio Control Head

1. How to remove

- (1) Remove the two screws (A) and remove the audio control head together with the head base.
- (2) When replacing only the audio control head, remove the three screws (B) while controlling the compression spring.

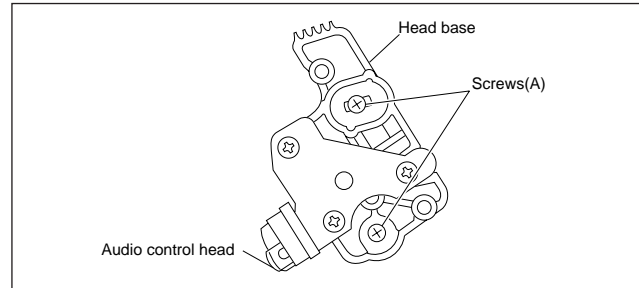

Fig. 2-2-6a

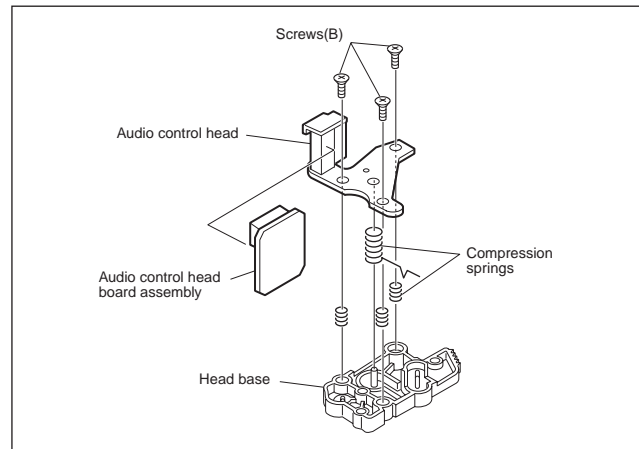

Fig. 2-2-6b

2. How to install

- (1) To make the post-installation adjustment easier, set the temporary level as indicated in Fig.2-2-6c. Also make sure that the screw center (centre) is brought into alignment with the center (centre) position of the slot.

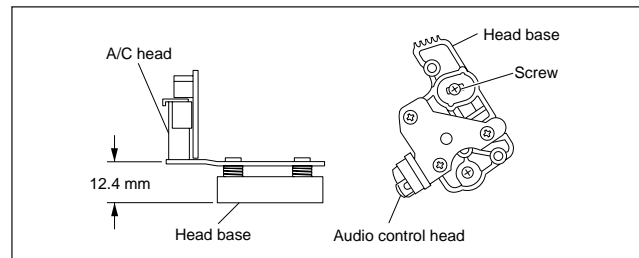

Fig. 2-2-6c

2.2.7 Loading Motor

1. How to remove

- (1) Remove the belt wound around the worm gear.
- (2) Open the two lugs of the motor guide and remove the loading motor, loading motor board assembly and motor guide altogether by pulling them up.
- (3) When replacing the loading motor board assembly, take care with the orientation of the loading motor. (Install so that the loading motor label faces upward.)
- (4) When the motor pulley has been replaced, choose the fitting dimension as indicated in Fig.2-2-7a.

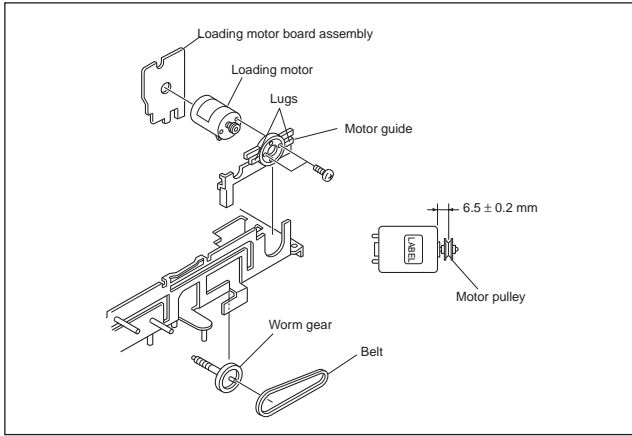

Fig. 2-2-7a

2.2.8 Capstan Motor

1. How to remove

- (1) Remove the belt (capstan) on the mechanism assembly back side.
- (2) Remove the three screws (A) and remove the capstan motor.

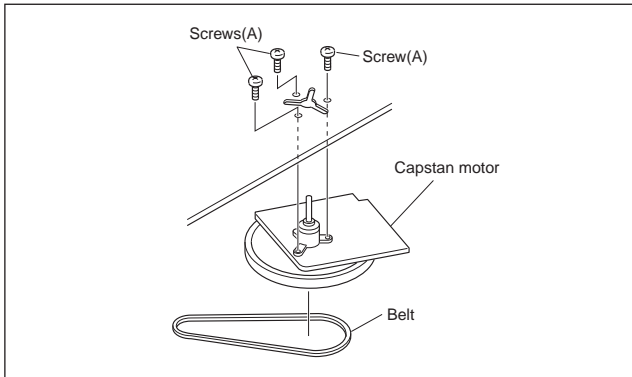

Fig. 2-2-8a

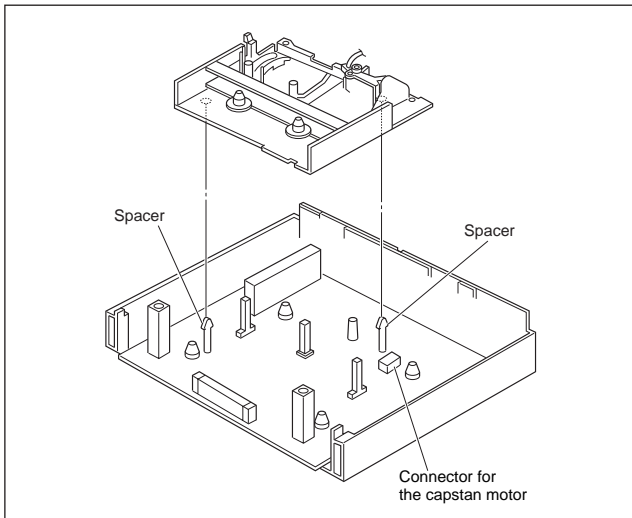

Fig. 2-2-8b

2. How to install (Centering the mounting position)

When the capstan motor has once been removed and then reinstalled out of the initial correct position in the rotational direction, the capstan motor current may be unstable during operation in high or low temperatures. This may result in greater Wow & Flutter and occasionally in power breakdown because of current over - load. Install the capstan motor while following the procedure given below.

(The capstan motor is centrally located when the unit is shipped from the factory.)

- (1) Provisionally tighten the three screws (A) securing the capstan motor.
- (2) Install the mechanism assembly to which the capstan motor is provisionally fastened on the bottom chassis which incorporates the Main board assembly. (No need to tighten the screws for mounting the mechanism.)
Make sure that all the connectors for the mechanism assembly and the Main board assembly are correctly installed as indicated in Fig. 2-2-8b.
- (3) Making sure that the connector for the capstan motor is correctly mounted, and securely tighten the three screws (A).

Note:

- **When the capstan motor has been replaced with a new one, perform recording in the EP(or LP) mode for at least 2 minutes at normal temperatures immediately before starting the FF/REW or SEARCH operations (Aging).**

2.2.9 Pole Base Assembly (supply or take-up side)

1. How to remove

- (1) Remove the UV catcher 2 on the removal side by loosening the screw (A).
- (2) Remove the pole base assembly on the supply side from the mechanism assembly by loosening the screw (B) on the mechanism assembly back side and sliding the pole base assembly toward the UV catcher 2.
- (3) As for the pole base assembly on the take-up side, turn the pulley of the loading motor to lower the cassette holder because the screw (B) is hidden under the control plate. (See the "Procedures for Lowering the Cassette holder assembly" of 1.3 DISASSEMBLY/ASSEMBLY METHOD.) Further turn the motor pulley to move the cassette holder until the screw (B) is no longer under the control plate (in the half-loading position). Then remove it as done for the supply side by removing the screw (B).

Note:

- **After reinstalling the Pole base assembly and the UV catcher2, be sure to perform compatibility adjustment.**

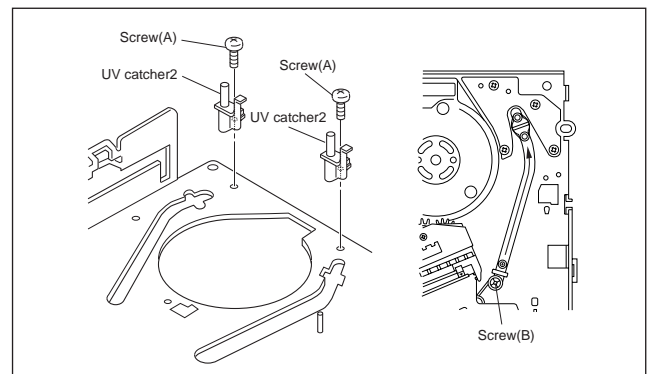

Fig. 2-2-9a

2.2.10 Rotary Encoder

1. How to remove

- (1) Remove the screw (A) and remove the rotary encoder by pulling it up. (See Fig. 2-2-10a.)

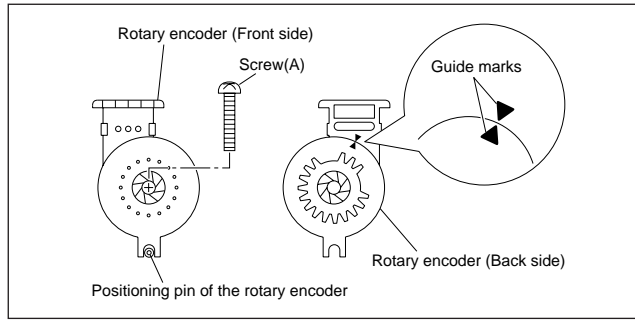

Fig. 2-2-10a

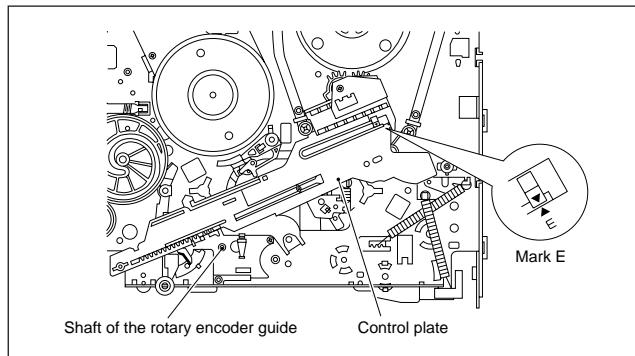

Fig. 2-2-10b

2. How to install (Phase matching)

- (1) Make sure that the mark E of the control plate is in alignment with the mark ▼ of the loading arm gear shaft and bring the guide marks on the rotary encoder into alignment as indicated in Fig.2-2-10a. (See Fig. 2-2-10a and Fig. 2-2-10b.)
- (2) Turn over the rotary encoder with its guide marks kept in alignment and install it by fitting on the shaft of the rotary encoder guide and the positioning pin.
- (3) Tighten the screw (A) to complete the installation.

2.2.11 Clutch Unit

- (1) Remove the belt wound around the capstan motor and the clutch unit.
- (2) Remove the slit washer and remove the clutch unit.

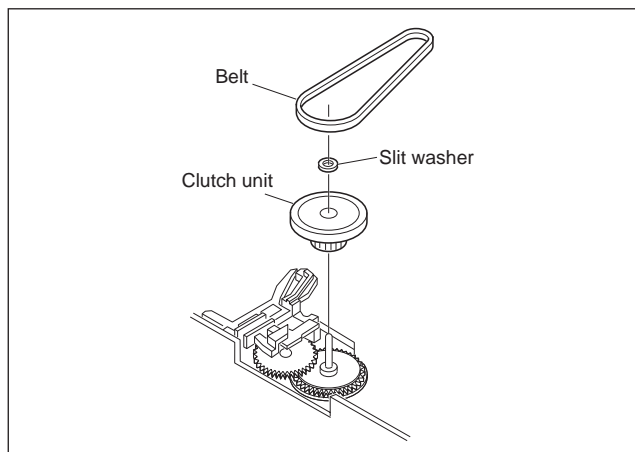

Fig. 2-2-11a

2.2.12 Change Lever Assembly, Direct Gear, Clutch Gear and Coupling Gear

1. How to remove

- (1) Release the two lugs of the rotary encoder guide in the arrow-indicated direction and remove the change lever assembly.
- (2) Remove the slit washer retaining the direct gear and remove the latter. Take care so as not to lose the washer and spring. (See Fig.2-2-12a.)

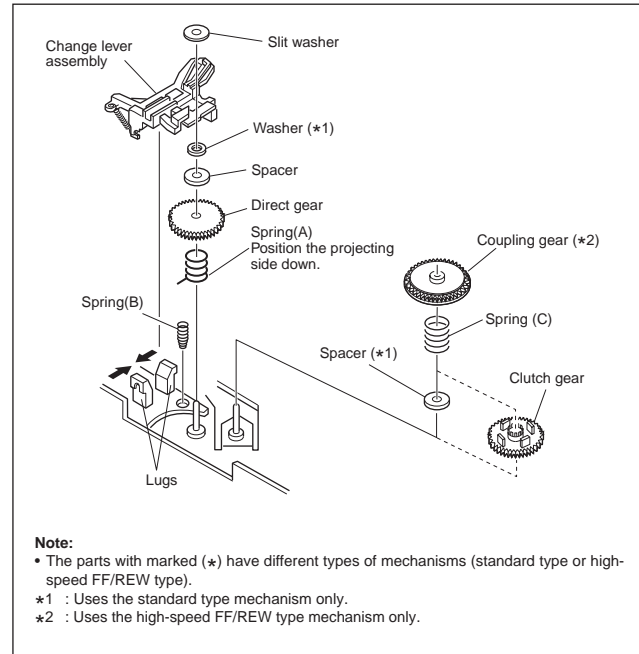

Fig. 2-2-12a

2. How to install

- (1) Install the clutch gear, spring (A), spring (C), direct gear, spacer and others to the individual shafts of the main deck, and finally the slit washer. (See Fig.2-2-12a.)
- (2) Let the spring (B) drops into the rotary encoder guide hole and install the change lever assembly.(Take care not to mistake a direction of the spring.) The point is to slightly lift the coupling gear and catch it from the both sides with the assembly. (See Fig.2-2-12b.)

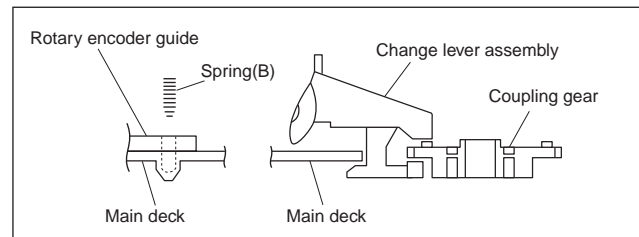

Fig. 2-2-12b

2.2.13 Link Lever

1. How to remove

- (1) Remove the two slit washers.
- (2) Remove the link lever by lifting it from the shaft retained by the slit washers. Then swing the link lever counterclockwise and remove it from the locking section of the control plate.

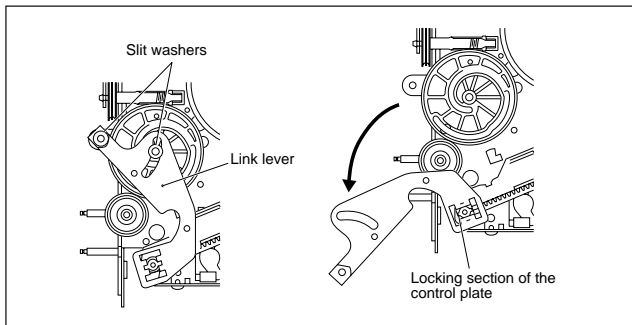

Fig. 2-2-13a

2. How to install (Phase matching)

- (1) Slide the control plate so that its mark E is aligned with the mark ▼ on the loading arm gear shaft. (See Fig.2-2-13b.)
- (2) Rotate the worm gear until the guide hole of the control cam is aligned exactly with the guide hole of the main deck. (See Fig.2-2-13c.)
- (3) Insert the link lever into the locking section of the control plate. (See Fig.2-2-13a.)
- (4) Rotate the link lever clockwise so that it is installed on the shafts in the center (centre) and on the left of the control cam.
- (5) Fasten the slit washers at these two points.

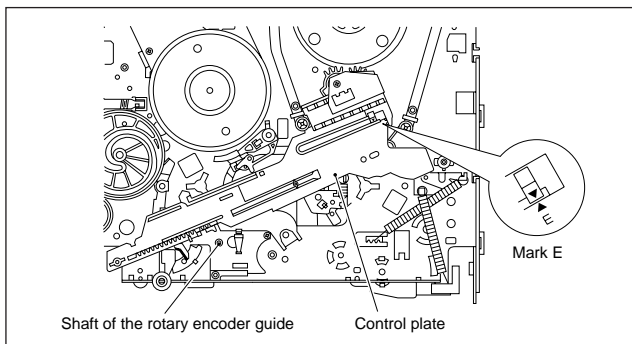

Fig. 2-2-13b

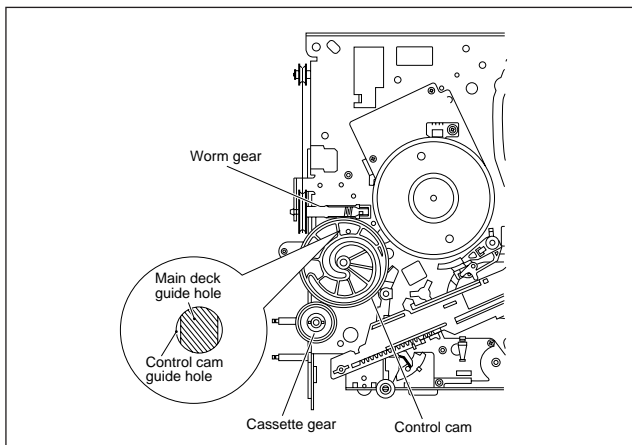

Fig. 2-2-13c

2.2.14 Cassette Gear, Control Cam and Worm Gear

1. How to remove

- (1) Remove the control cam by lifting it.
- (2) Open the two lugs of the cassette gear outward and pull the latter off.
- (3) Remove the belt wound around the worm gear and the loading motor.
- (4) Open the lug of the lid guide outward and remove the worm gear.

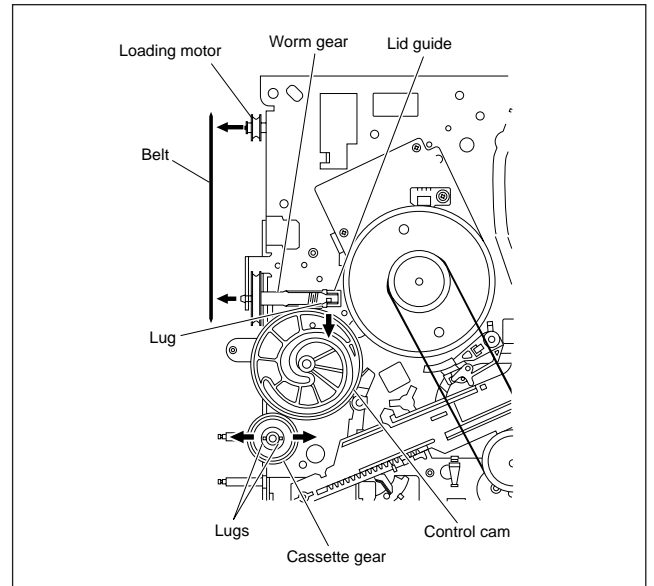

Fig. 2-2-14a

2.2.15 Control Plate

1. How to remove

- (1) Remove the screw (A) retaining the control bracket 1 and remove the latter.
- (2) Slide the control plate as indicated by the arrow and remove the control plate. (See Fig.2-2-15a.)

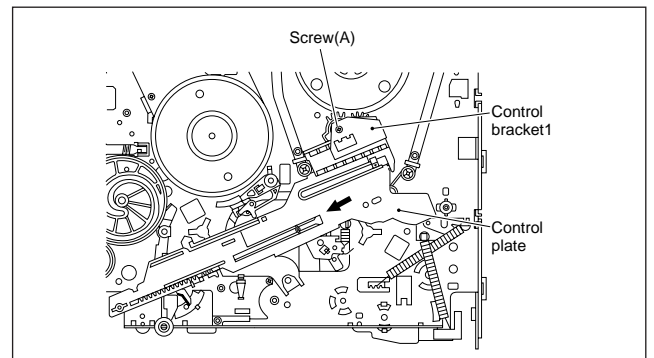

Fig. 2-2-15a

2. How to install (Phase matching)

- (1) Adjust the position of the idler arm assembly pin as indicated in Fig.2-2-15b (to the left of center (centre) of the R section).
- (2) Bring the guide hole of the take-up lever into alignment with the hole at the control plate guide and fix the position by inserting a 1.5 mm hexagonal wrench.

- (3) Install the control plate so that the section A of the loading arm gear shaft fits into the hole (A) of the control plate, the section B of the control plate guide into the hole (B), and the control plate comes under the section C of the rotary encoder guide and the section D of the loading arm gear shaft while press-fit the pole base assembly (supply side) as indicated by the arrow. It is important that the tension arm assembly shaft is positioned closer toward you than the control plate. (See Fig.2-2-15c.)
- (4) Make sure that the mark E of the control plate is in alignment with the mark ▼ of the loading arm gear shaft. (See Fig.2-2-15c.)
- (5) Pull off the hexagonal wrench for positioning.

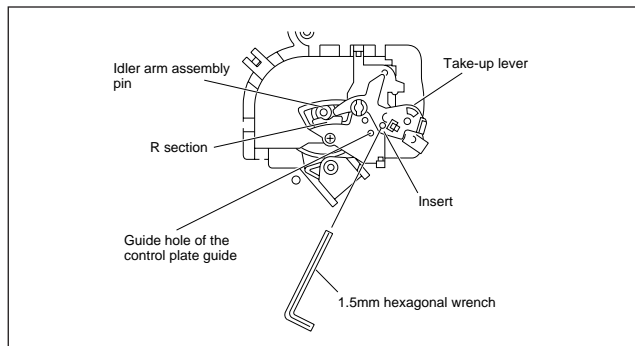

Fig. 2-2-15b

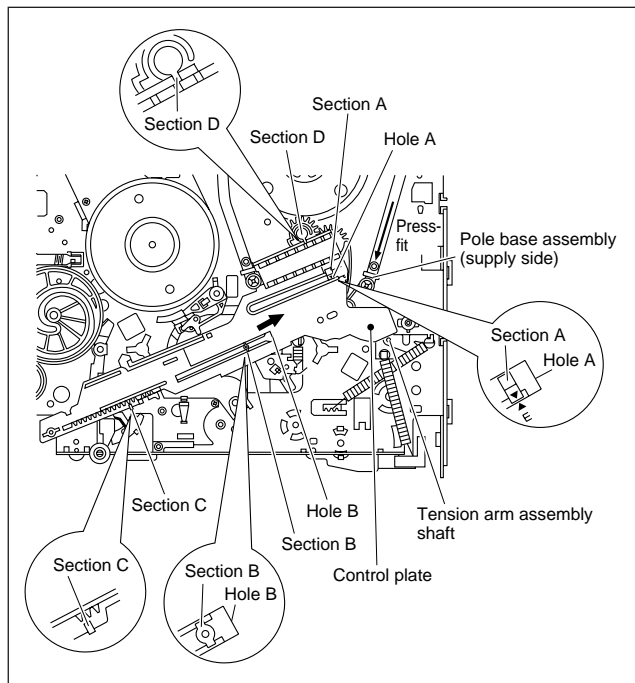

Fig. 2-2-15c

2.2.16 Loading Arm Gear (supply or take-up side) and Loading Arm Gear Shaft

1. How to remove

- (1) Remove the loading arm gear (supply side) by loosening the screw (A). (See Fig. 2-2-16a.)
- (2) Remove the screw (B) and remove the torsion arm from the pole base assembly (take-up side). (See Fig.2-2-16a.)

- (3) Turn the loading arm gear (take-up side) clockwise so that the notch of the loading arm gear (take-up side) is in alignment with the projection of the loading arm gear shaft and lift it. Likewise, turn the loading arm counterclockwise so that the notch is in alignment with the projection and remove the loading arm gear (take-up side). (See Fig.2-2-16a and Fig. 2-2-16b.)
- (4) When removing the loading arm gear shaft, be sure of first removing the screw retaining the drum assembly (on the back side of the loading arm gear shaft). Then remove the screw (C) and remove the loading arm gear shaft by sliding it.

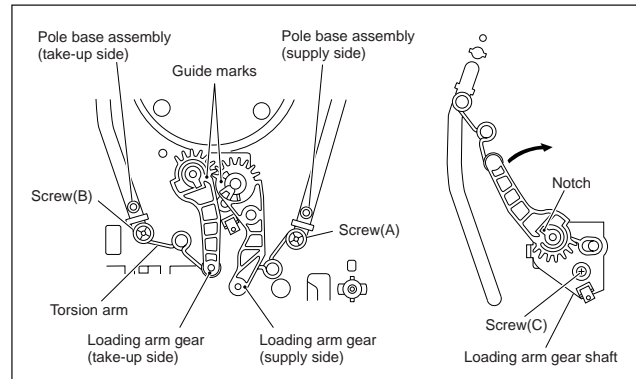

Fig. 2-2-16a

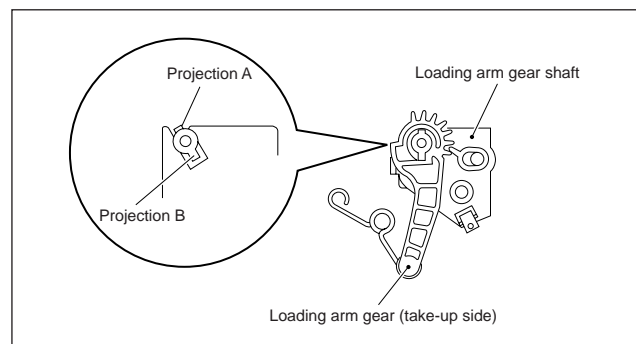

Fig. 2-2-16b

2. How to install

- (1) Align the notch of the loading arm gear (take-up side) to the projection B of the loading arm gear shaft and slip it over. Then rotate it clockwise for alignment with the projection A and slip it down to the bottom. (See Fig.2-2-16b.)
- (2) Then turn the loading arm gear (take-up side) counterclockwise. Hang the torsion arm on the pole base assembly (take-up side) and tighten the screw (B).
- (3) Install the loading arm gear (supply side) so that the guide mark of the loading arm gear (take-up side) is in alignment with the guide mark of the loading arm gear (supply side). Then hang the torsion arm on the pole base assembly (supply side) and tighten the screw (A). (See Fig.2-2-16a.)

2.2.17 Take-up Lever, Take-up Head and Control Plate Guide

- (1) Remove the spring of the take-up lever from the main deck.
- (2) Remove the lug (A) of the take-up lever from the main deck and pull out the take-up lever and the take-up head together.
- (3) Remove the screw (A).
- (4) Align the idler arm assembly pin in the center (centre) of the R section of the control plate guide, remove the control plate guide lugs (B) and (C) from the main deck, and remove the control plate guide.

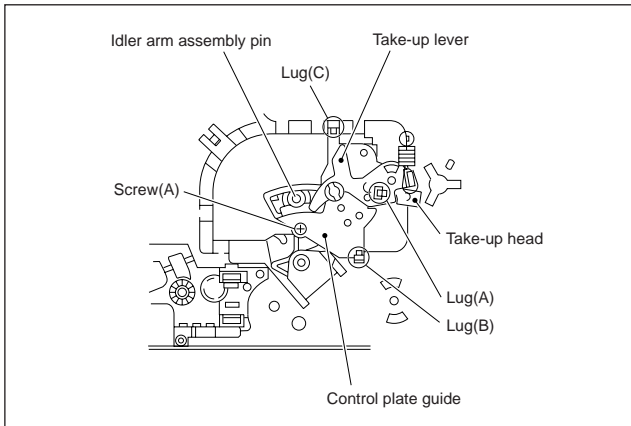

Fig. 2-2-17a

2.2.18 Capstan Brake Assembly

1. How to remove

- (1) Move the lug (A) of the capstan brake assembly in the arrow-indicated direction so that it comes into alignment with the notch of the main deck. (See Fig. 2-2-18a.)
- (2) Remove the lug (B) of the capstan brake assembly from the main deck and remove the capstan brake assembly.

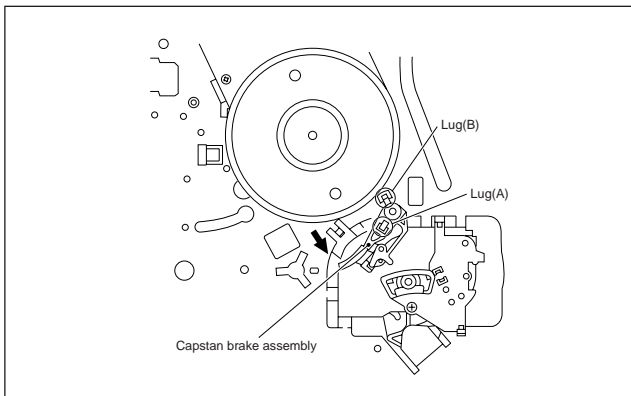

Fig. 2-2-18a

2.2.19 Sub Brake Assembly (take-up side)

1. How to remove

- (1) Remove the spring attached to the lid guide and sub brake assembly (take-up side).
- (2) Bring the lug (A) of the sub brake assembly (take-up side) into alignment with the notch of the main deck.
- (3) Remove the lugs (B) and (C) of the sub brake assembly (take-up side) from the main deck and remove the sub brake assembly (take-up side).

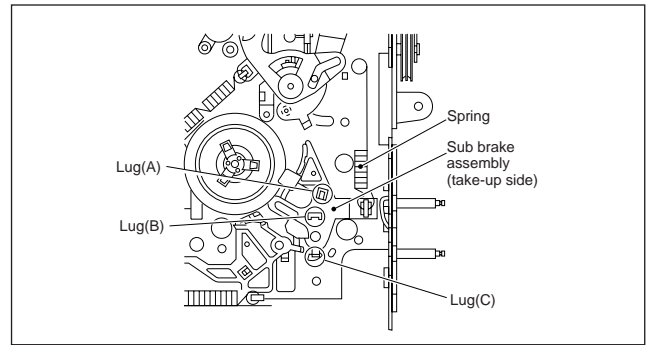

Fig. 2-2-19a

2.2.20 Main Brake Assembly (take-up side), Reel Disk (take-up side) and Main Brake Assembly (supply side)

1. How to remove

- (1) Move the main brake assembly (take-up side) in the arrow-indicated direction and remove the reel disk (take-up side).
- (2) Remove the spring attached to the main brake assembly.
- (3) Remove the lug (A) of the main brake assembly (take-up side) and pull out the lug (B) after bringing it into alignment with the main deck notch.
- (4) Remove the lugs (C), (D) and (E) of the main brake assembly (supply side) from the main deck and pull them off. (See Fig.2-2-20a.)
- (5) When installing the main brake assembly (take-up side), slide the brake lever in the direction as indicated by the arrow to prevent it from hitting the projection of the main brake assembly (take-up side). (See Fig.2-2-20b.)

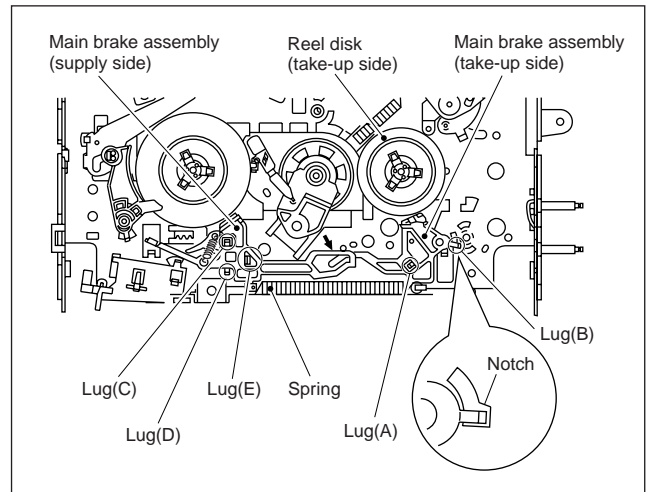
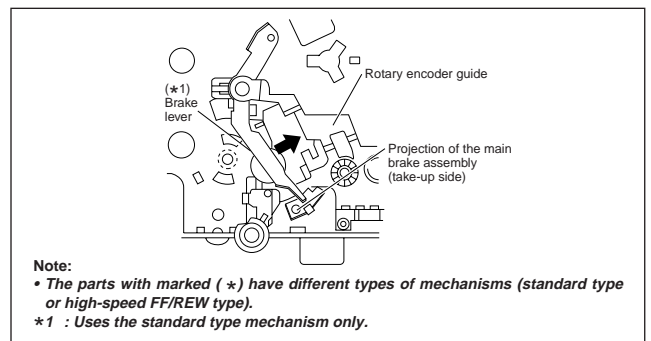

Fig. 2-2-20a



Note:
 • The parts with marked (*) have different types of mechanisms (standard type or high-speed FF/REW type).
 *1 : Uses the standard type mechanism only.

Fig. 2-2-20b

2.2.21 Tension Brake Assembly, Reel Disk (supply side) and Tension Arm Assembly

1. How to remove

- (1) Remove the three lugs of the tension brake assembly from the main deck and pull them off.
- (2) Remove the reel disk (supply side) by loosening in the arrow-indicated direction the main brake assembly (supply side).
- (3) Remove the tension spring on the back of the main deck. Then release the lug of the tension arm bearing in the arrow-indicated direction and draw out the tension arm assembly. (See Fig. 2-2-21a.)

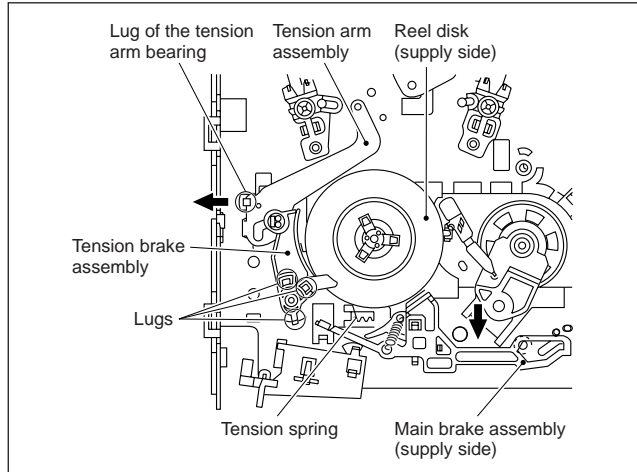

Fig. 2-2-21a

2.2.22 Idler Lever, Idler Arm Assembly

1. How to remove

- (1) Remove the lug of the idler lever from the main deck and remove the hook fitted in the idler arm assembly hole by lifting it.
- (2) Remove the slit washer and pull out the idler arm assembly.

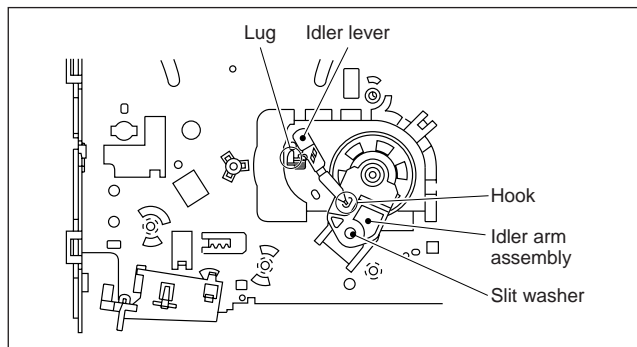

Fig. 2-2-22a

2.2.23 Stator Assembly

- (1) Remove the flat cable.
- (2) Remove the two screws (A).
- (3) Remove the stator assembly by lifting in the arrow-indicated direction. (Take care that the brush spring does not jump out.)
- (4) After installation, be sure to perform the PB switching point adjustment according to the electrical adjustment procedure.

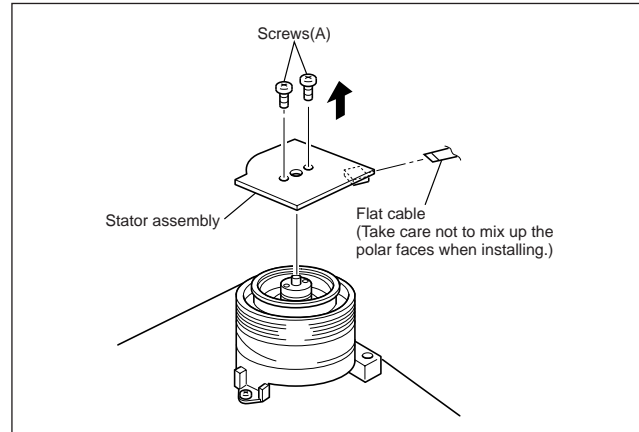

Fig. 2-2-23a

2.2.24 Rotor Assembly

- (1) Remove the stator assembly.
- (2) Remove the two screws (B) and remove the rotor assembly.

Note:

• **When installing the rotor assembly, note that a normal picture cannot be obtained without ensuring the phase matching as mentioned below.**

- (3) Match the phases of the upper drum assembly and the rotor assembly as indicated in Fig.2-2-24a.
- (4) Place the upper drum assembly hole (a) over the rotor assembly holes (b) (with three holes to be aligned) and tighten the two screws (B). (See Fig.2-2-24a.)

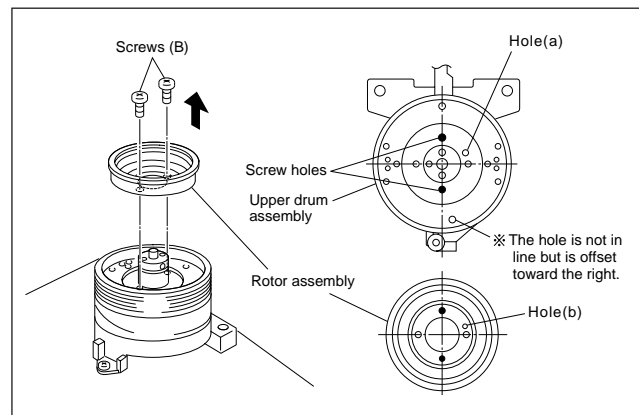

Fig. 2-2-24a

2.2.25 Upper Drum Assembly

Notes:

- **To replace the upper drum assembly only may not be possible with some models. For upper drum assembly replacement, refer to the parts list. (When the parts number of the upper drum assembly is not listed on the parts list, then this cannot be replaced.)**

1. How to remove

- (1) Remove the stator assembly and rotor assembly.
- (2) Loosen the screw of the collar assembly using a 1.5 mm hexagonal wrench and remove the collar assembly. Also remove the brush, spring and cap at one time.
- (3) Remove the upper drum assembly and remove the washer using tweezers.

Note:

- **When replacement is required, control the up- down movement of the brush. Never apply grease.**

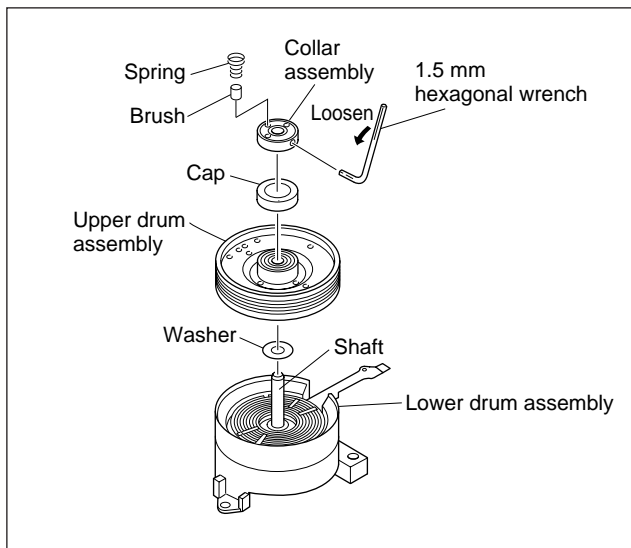

Fig. 2-2-25a

2. How to install

- (1) Clean the coil parts of the lower drum assembly and the newly installed upper drum assembly with an air brush in advance. (See Fig.2-2-25b.)
- (2) Install a new washer and upper drum assembly on the drum shaft. (See Fig.2-2-25a.)

Note:

- **When replacing the upper drum assembly, replace it together with the washer.**

- (3) Install the cap to the upper drum assembly.
- (4) Position the collar assembly as indicated in Fig.2-2-25c while controlling its up- down movement.
- (5) Secure the collar assembly in position with a hexagonal wrench while pressing its top with the fingers.
- (6) After installation, gently turn the upper drum assembly with your hand to make sure that it turns normally. Then install the brush and the spring.
- (7) Install the rotor assembly and stator assembly according to Fig 2-2-23a and 2-2-24a.
- (8) When installation is complete, clean the upper drum assembly and lower drum assembly and carry out the following adjustments.

- PB switching point adjustment
- Slow tracking adjustment
- Compatibility adjustment (Be sure to check for compatibility for the EP (or LP) mode.)

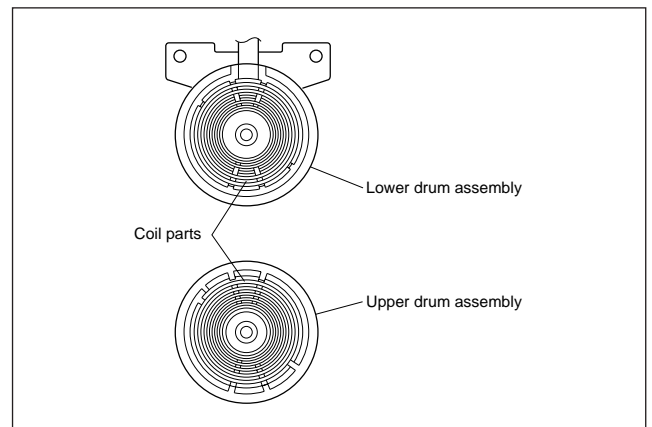

Fig. 2-2-25b

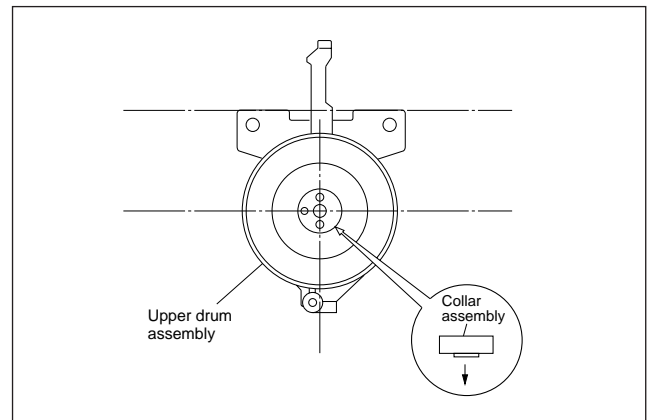

Fig. 2-2-25c

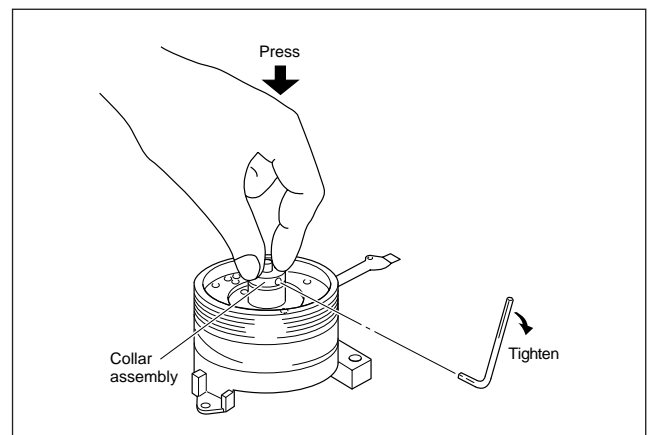

Fig. 2-2-25d

2.3 Compatibility adjustment

Notes:

- **Although compatibility adjustment is very important, it is not necessary to perform this as part of the normal servicing work. It will be required when you have replaced the A/C head, drum assembly or any part of the tape transport system.**
- **To avoid any damage to the alignment tape while performing the compatibility adjustment, get a separate cassette tape (for recording and play back) ready to be used for checking the initial tape running behavior.**
- **Unless otherwise specified, all measuring points and adjustment parts are located on the Main board.**
- **When using the Jig RCU, it is required to set the VCR to the Jig RCU mode (the mode in which codes from the Jig RCU can be received). (See SECTION 1 DISASSEMBLY.)**

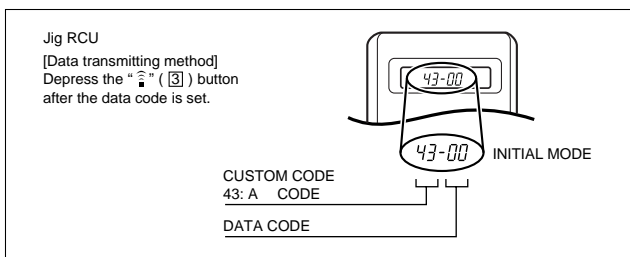

Fig. 2-3a Jig RCU [PTU94023B]

2.3.1 FM waveform linearity

Signal	(A1) (A2)	• Alignment tape(SP, stairstep, PAL) [MHPE] • Alignment tape(LP, stairstep, PAL) [MHPE-L]
Mode	(B)	• PB
Equipment	(C)	• Oscilloscope
Measuring point	(D)	• TP106 (PB, FM)
External trigger	(E)	• TP111 (D,FF)
Adjustment part	(F)	• Guide roller [Mechanism assembly]
Specified value	(G)	• Flat V.PB FM waveform
Adjustment tool	(H)	• Roller driver [PTU94002]

- (1) Play back the alignment tape (A1).
- (2) Apply the external trigger signal to D.FF (E), to observe the V.PB FM waveform at the measuring point (D).
- (3) Set the VCR to the manual tracking mode.
- (4) Make sure that there is no significant level drop of the V.PB FM waveform caused by the tracking operation, with its generally parallel and linear variation ensured. Perform the following adjustments when required. (See Fig. 2-3-1a.)
- (5) Reduce the V.PB FM waveform by the tracking operation. If a drop in level is found on the left side, turn the guide roller of the pole base assembly (supply side) with the roller driver to make the V.PB FM waveform linear. If a drop in level is on the right side, likewise turn the guide roller of the pole base assembly (take-up side) with the roller driver to make it linear. (See Fig. 2-3-1c.)
- (6) Make sure that the V.PB FM waveform varies in parallel and linearly with the tracking operation again. When required, perform fine-adjustment of the guide roller of the

- (7) Unload the cassette tape once, play back the alignment tape (A1) again and confirm the V.PB FM waveform.
- (8) After adjustment, confirm that the tape wrinkling does not occur at the roller upper or lower limits. (See Fig. 2-3-1d.)

[Perform adjustment step (9) only for the models equipped with SP mode and EP (or LP) mode.]

- (9) Repeat steps (1) to (8) by using the alignment tape (A2).

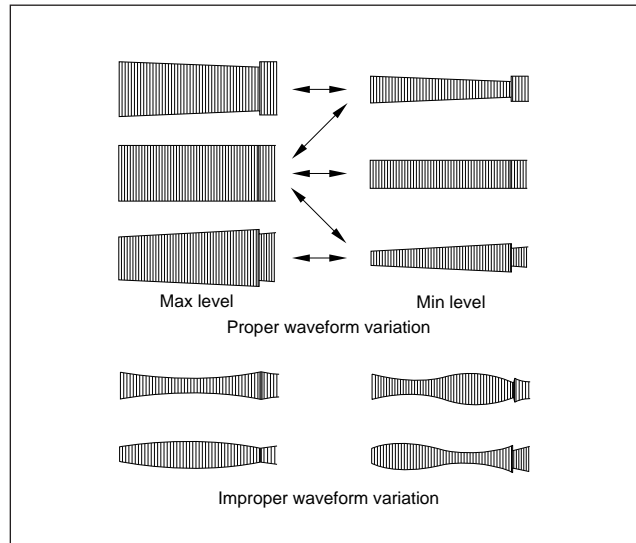

Fig. 2-3-1a

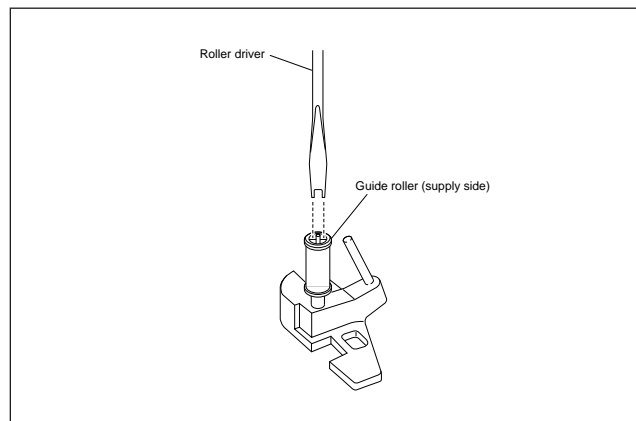

Fig. 2-3-1b

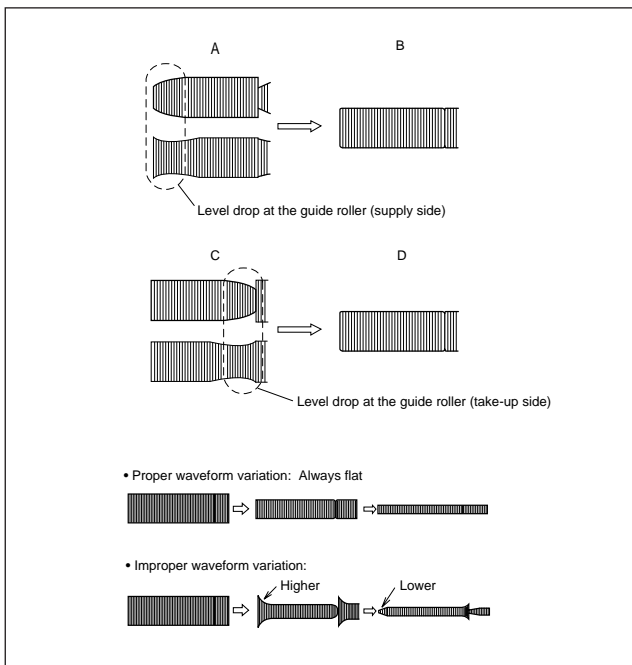

Fig. 2-3-1c

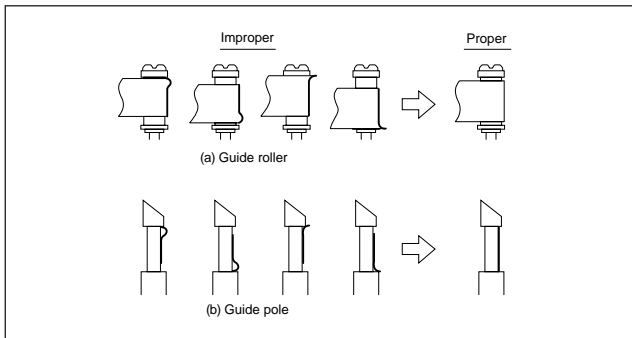

Fig. 2-3-1d

2.3.2 Height and tilt of the A/C head

Note:

- **Set a temporary level of the height of the A/C head in advance to make the adjustment easier after the A/C head has been replaced. (See Fig.2-2-6c.)**

Signal	(A)	• Alignment tape(SP, stairstep,PAL) [MHPE]
Mode	(B)	• PB
Equipment	(C)	• Oscilloscope
Measuring point	(D1) (D2)	• AUDIO OUT terminal • TP4001 (CTL. P)
External trigger	(E)	• TP111 (D.FF)
Adjustment part	(F)	• A/C head [Mechanism assembly]
Specified value	(G)	• Maximum waveform

- (1) Play back the alignment tape (A).
- (2) Apply the external trigger signal to D.FF (E), to observe the AUDIO OUT waveform and Control pulse waveform at the measuring points (D1) and (D2) in the ALT mode.
- (3) Set the VCR to the manual tracking mode.

- (4) Adjust the AUDIO OUT waveform and Control pulse waveform by turning the screws (1), (2) and (3) little by little until both waveforms reach maximum. The screw (1) and (3) are for adjustment of tilt and the screw (2) for azimuth.

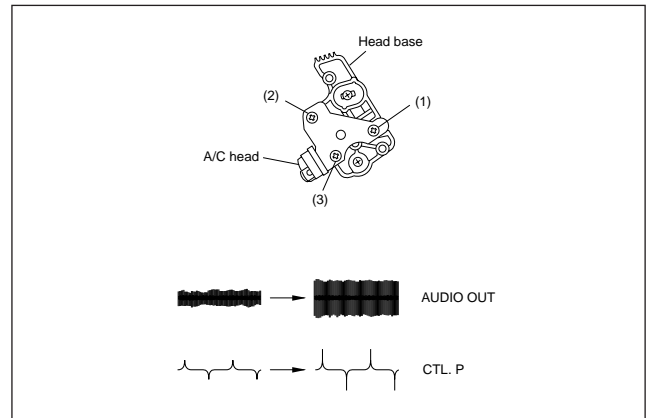

Fig. 2-3-2a

2.3.3 A/C head phase (X-value)

Signal	(A1)	• Alignment tape(SP, stairstep,PAL) [MHPE]
Mode	(B)	• PB
Equipment	(C)	• Oscilloscope
Measuring point	(D)	• TP106 (PB. FM)
External trigger	(E)	• TP111 (D.FF)
Adjustment part	(F)	• A/C head base [Mechanism assembly]
Specified value	(G)	• Maximum V.PB FM waveform
Adjustment tool	(H)	• A/C head positioning tool [PTU94010]

- (1) Play back the alignment tape (A1).
- (2) Apply the external trigger signal to D.FF (E), to observe the V.PB FM waveform at the measuring point (D).
- (3) Set the VCR to the manual tracking mode.
- (4) Loosen the screws (4) and (5), then set the A/C head positioning tool to the innermost projected part of the A/C head. (See Fig. 2-3-3a.)
- (5) Turn the A/C head positioning tool fully toward the capstan. Then turn it back gradually toward the drum and stop on the second peak point position of the V.PB FM waveform output level. Then tighten the screws (4) and (5).
- (6) Perform the tracking operation and make sure that the V.PB FM waveform is at its maximum. If it is not at maximum, loosen the screws (4) and (5), and turn the A/C head positioning tool to bring the A/C head to a position, around where the waveform reaches its maximum for the first time. Then tighten the screws (4) and (5).

[Perform adjustment steps (7) to (10) only for 2 Head models equipped with LP mode.]

- (7) Then play back the alignment tape (A2).
- (8) Set the VCR to the manual tracking mode.
- (9) Perform the tracking operation and make sure that the V.PB FM waveform is at its maximum.
- (10) If it is not at maximum, loosen the screws (4) and (5), and turn the A/C head positioning tool to bring the A/C head to a position, around where the waveform reaches its maximum for the first time. Then tighten the screws (4) and (5).

Note:

- After adjusting, always perform the confirmation and re-adjustment of the item 2.3.4.

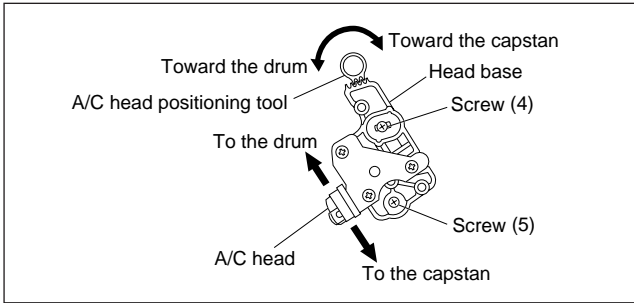

Fig. 2-3-3a

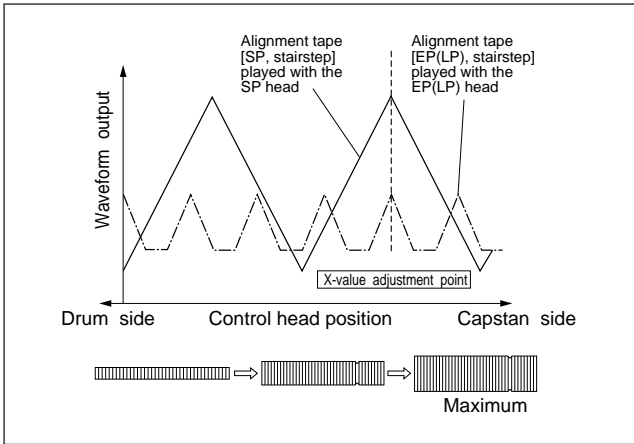

Fig. 2-3-3b

2.3.4 Standard tracking preset

Signal	(A)	• Alignment tape(LP, stairstep, PAL) [MHPE-L]
Mode	(B)	• PB → Auto adjust
Equipment	(C)	• Oscilloscope
Measuring point	(D)	• TP106 (PB. FM)
External trigger	(E)	• TP111 (D.FF)
Adjustment part	(F)	• Jig RCU: Code "50"
Specified value	(G)	• STOP mode (Maximum V.PB FM waveform)
Adjustment tool	(H)	• Jig RCU [PTU94023B]

- (1) Play back the alignment tape (A).
- (2) Apply the external trigger signal to D.FF (E), to observe the V.PB FM waveform at the measuring point (D).
- (3) Confirm that the automatic tracking operation is completed.

- (4) Set the VCR to the Auto adjust mode by transmitting the code (F) twice from the Jig RCU. When the VCR enters the stop mode, the adjustment is completed.
- (5) If the VCR enters the eject mode, perform adjustment for the audio control head phase (X-value) again.

2.3.5 Tension pole position

Signal	(A)	• Back tension cassette gauge [PUJ48076-2]
Mode	(B)	• PB
Adjustment part	(F)	• Adjust pin [Mechansim assembly]
Specified value	(G)	• 25 - 51 gf•cm (2.45 - 5 × 10 ⁻³ Nm)

- (1) Play back the back tension cassette gauge (A).
- (2) Check that the indicated value on the left side gauge is within the specified value (G).
- (3) If the indicated value is not within the specified value (G), perform the adjustment in a following procedure.
 - 1) Set the VCR to the mechanism service mode. (See SECTION 1 DISASSEMBLY.)
 - 2) Set the VCR to the play back mode and adjust by turning adjustment pin to align the tension arm assembly edge with the main deck hole (A) on the right edge marker. (See Fig. 2-3-5a)

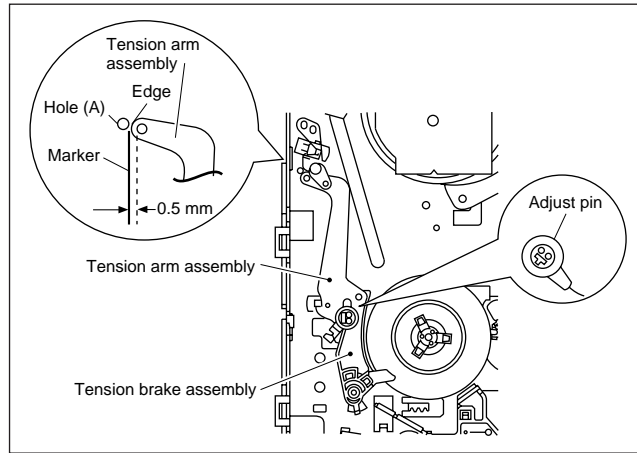
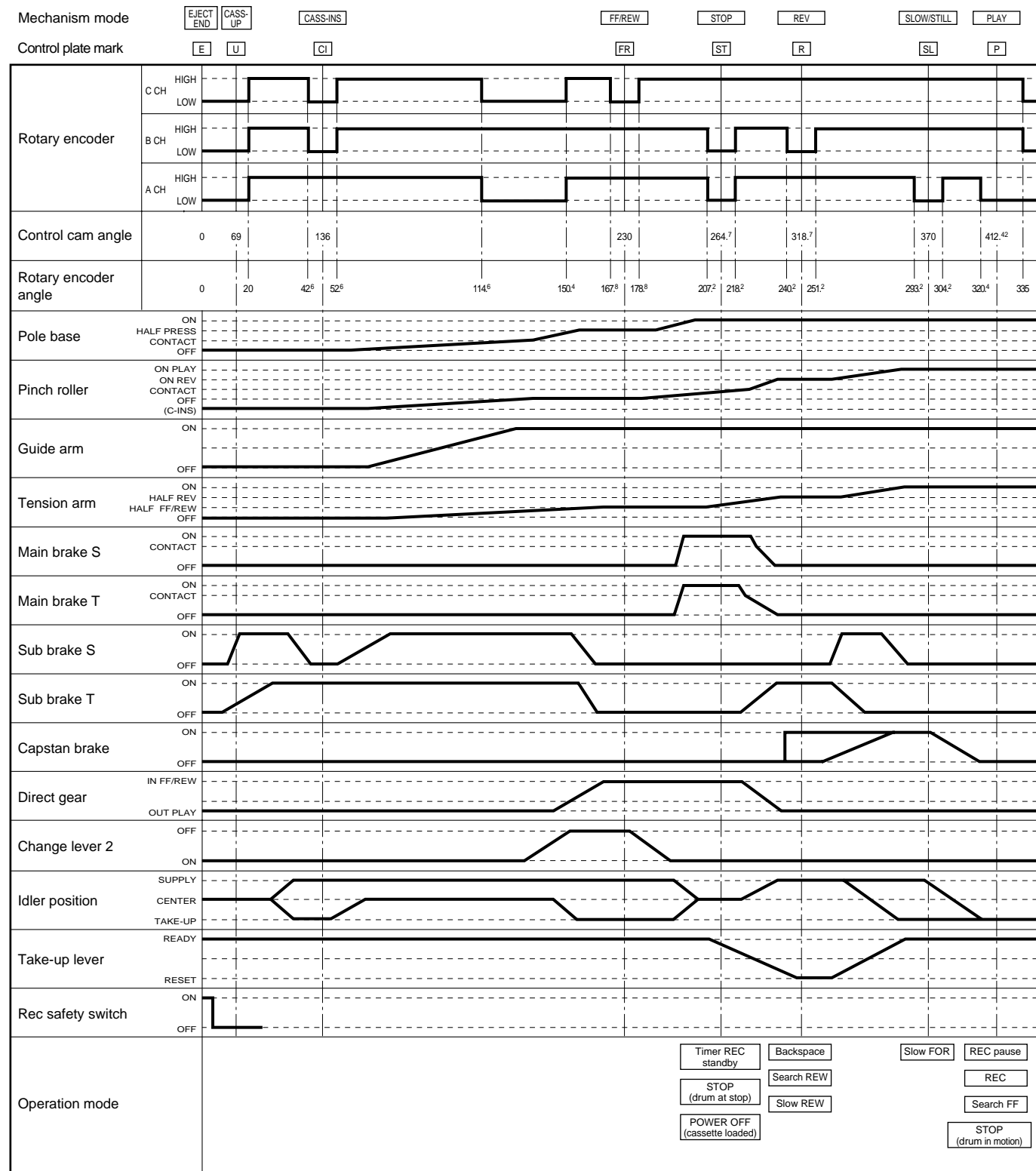

Fig. 2-3-5a

Mechanism Timing Chart



SECTION 3 ELECTRICAL ADJUSTMENT

3.1 Precaution

The following adjustment procedures are not only necessary after replacement of consumable mechanical parts or board assemblies, but are also provided as references to be referred to when servicing the electrical circuitry.

In case of trouble with the electrical circuitry, always begin a service by identifying the defective points by using the measuring instruments as described in the following electrical adjustment procedures. After this, proceed to the repair, replacement and/or adjustment. If the required measuring instruments are not available in the field, do not change the adjustment parts (variable resistor, etc.) carelessly.

3.1.1 Required test equipments

- Color (colour) television or monitor
- Oscilloscope: wide-band, dual-trace, triggered delayed sweep
- Signal generator: RF / IF sweep / marker
- Audio level meter
- Signal generator: stairstep, color (colour) bar [PAL/NTSC]
- Recording tape
- Digit-key remote controller(provided)

3.1.2 Required adjustment tools

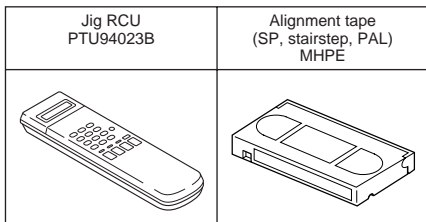

3.1.3 Color (colour) bar signal, color (colour) bar pattern

- Color(colour) bar signal [PAL]
- Color(colour) bar pattern [PAL]

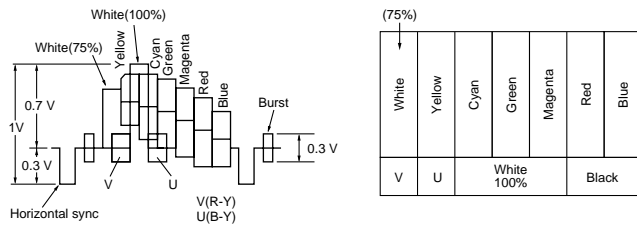

- Color(colour) bar signal [NTSC]
- Color(colour) bar pattern [NTSC]

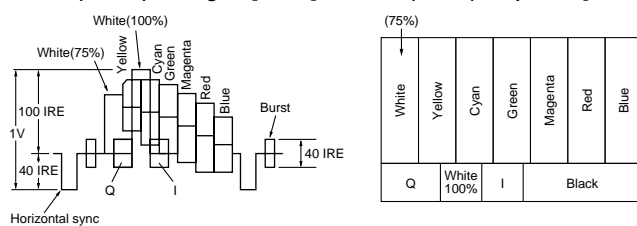

3.1.4 Switch settings and standard precautions

The SW settings of the VCR and the standard precautions for the electrical adjustments are as follows.

- **When using the Jig RCU, it is required to set the VCR to the Jig RCU mode (the mode in which codes from the Jig RCU can be received). (See SECTION 1 DIS-ASSEMBLY.)**

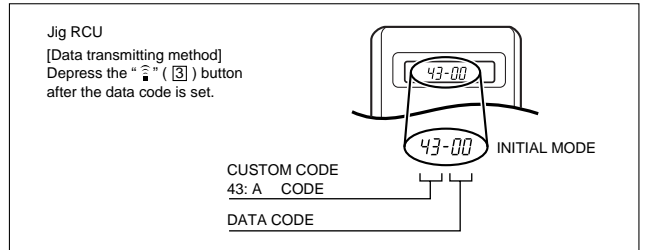

Fig. 3-1-4a Jig RCU [PTU94023B]

- **Set the switches as shown below unless otherwise specified on the relevant adjustment chart. The switches that are not listed below can be set as desired. If the VCR is not equipped with the functions detailed below, setup is not required.**

AUTO PICTURE/VIDEO CALIBRATION/ B.E.S.T./D.S.P.C.	OFF
PICTURE CONTROL/SMART PICTURE	NORMAL/NATURAL
VIDEO STABILIZER	OFF
TBC	ON
Digital 3R	ON
VIDEO NAVIGATION/TAPE MANAGER	OFF

- **If there is a reference to a signal input method in the signal column of the adjustment chart, "Ext. S-input" means the Y/C separated video signal and "Ext. input" means the composite video signal input.**
- **Unless otherwise specified, all measuring points and adjustment parts are located on the Main board.**

3.2 Servo circuit

3.2.1 Switching point

Note: For models that applied with TBC, turn off TBC.

Signal	(A1) (A2)	• Stairstep signal • Alignment tape (SP,stairstep,PAL) [MHPE]
Mode	(B)	• PB
Equipment	(C)	• Oscilloscope
Measuring point	(D1) (D2)	• VIDEO OUT terminal (75Ω terminated) • TP106 (PB. FM)
External trigger	(E)	• TP111 (D.FF)/slope : -
Adjustment part	(F)	• Jig RCU: Code "5A"
Specified value	(G)	• 6.5 ± 0.5H
Adjustment tool	(H)	• Jig RCU [PTU94023B]

- Play back the signal (A1) of the alignment tape (A2).
- Apply the external trigger signal to D.FF (E) to observe the VIDEO OUT waveform and V.PB FM waveform at the measuring points (D1) and (D2).
- Set the VCR to the manual tracking mode.
- Adjust tracking so that the V.PB FM waveform becomes maximum.
- Set the VCR to the Auto adjust mode by transmitting the code (F) from the Jig RCU. When the VCR enters the stop mode, the adjustment is completed.
- If the VCR enters the eject mode, repeat steps (1) to (5) again.
- Play back the alignment tape (A2) again, confirm that the switching point is the specified value (G).

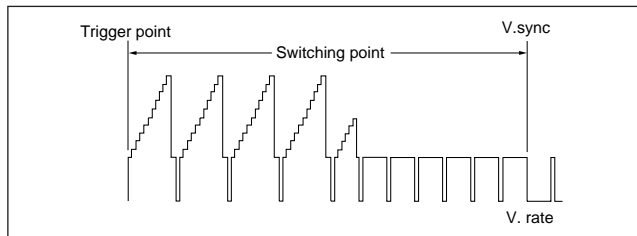

Fig. 3-2-1a Switching point

3.2.2 Slowtracking preset

Signal	(A1) (A2) (A3)	• Ext. input • Color (colour) bar signal [PAL] • Color (colour) bar signal [NTSC]
Mode (Notes)	(B1) (B2) (B3) (B4)	• VHS SP] (PAL) • VHS LP] • VHS SP] (NTSC) • VHS EP]
Measuring point	(D)	• TV-Monitor
Adjustment part	(F)	• Jig RCU: Code "71" or "72"
Specified value	(G)	• Minimum noise
Adjustment tool	(H)	• Jig RCU [PTU94023B]

- Record the signal (A2) in the mode (B1), and play back the recorded signal.
- Press the channel buttons (+, -) simultaneously to enter the manual tracking mode. This also brings tracking to the center (centre).
- Set the VCR to the FWD slow (+1/6x) mode.
- Transmit the code (F) from the Jig RCU to adjust so that the noise bar becomes the specified value (G) on the TV monitor in the slow mode.

- Set the VCR to the Stop mode.
- Confirm that the noise bar is (G) on the TV monitor in the slow mode.
- Repeat steps (3) to (6) in the REV slow (-1/6x) mode.
- Repeat steps (1) to (7) in the mode (B2).
- Record the signal (A3) in the mode (B3), and play back the recorded signal.
- Repeat steps (2) to (7).
- Repeat steps (9) and (10) in the mode (B4).

Note:

- For FWD slow (+1/6x) playback, transmit the code "08" from the Jig RCU to enter the slow playback mode, and transmit the code "D0" for REV slow (-1/6x) mode.
- The model which does not correspond for REV slow gives procedures of step 7 in SKIP.

3.3 Video circuit

3.3.1 Auto picture initial setting

Signal	(A1) (A2) (A3)	• Ext. input • Video: Optional • VHS tape
Mode	(B)	• EE → Auto adjust (SP/LP REC → PB)
Adjustment part	(F)	• Jig RCU : Code "58"
Specified value	(G)	• STOP mode
Adjustment tool	(H)	• Jig RCU [PTU94023B]

- Insert the cassette tape (A3).
- Set the VCR to the Auto adjust mode by transmitting the code (F) from the Jig RCU. When the VCR enters the stop mode, the adjustment is completed. When the VCR enters the eject mode, repeat steps (1) to (2) again.

3.4 Syscon circuit

Note:

- When perform this adjustment, remove the Mechanism assembly.

3.4.1 Timer clock

Signal	(A)	• No signal
Mode	(B)	• EE
Equipment	(C)	• Frequency counter
Measuring point	(D1)	• IC3001 pin29
Short point	(D2) (D3) (D4)	• IC3001 pin56 • IC3001 pin57 • IC3001 pin25
Adjustment part	(F)	• C3018 (TIMER CLOCK)
Specified value	(G)	• 1024.008 ± 0.001 Hz (976.554 ± 0.001 μsec)

- Connect the frequency counter to the measuring point (D1).
- Connect the short wire between the short point (D2) and GND.
- Connect the short wire between the short point (D3) and GND.
- Connect the short wire between the short point (D4) and GND in order to reset the microprocessor of the SYSCON.
- Disconnect the short wire of step (3).
- Adjust the Adjustment part (F) so that the output frequency becomes the specified value (G).

JVC

VICTOR COMPANY OF JAPAN, LIMITED
VIDEO DIVISION

S40894